

Tuchel - Simply clean!

Road sweepers

Snow blades / Snow plows

Vehicles

General
catalogue



GB

TUCHEL
MASCHINENBAU GmbH



Dieter Beckmann
(Managing Director)

Dear customer!

When you are satisfied with our products, when our machines facilitate your daily work, when we have entirely realized your requirements, then we've done a good job!

For the development of our products we focus on the input from our customers, pick up thoughts and ideas and orientate ourselves on what practitioners suggest. Thus, we manufacture innovative machinery that doesn't only look brilliant, but which is of real benefit for the user, too.

Innovative power combined with high quality and a clear price-performance policy ensures product acceptance. Based on this main idea we've defined three cornerstones for our company's success:

Innovative solutions – In collaboration with our customers we develop solutions for everyday problems. Our engineers do also work outdoor, at the front line, not only on the computer!

Durable products – They form the measurable basis for customer satisfaction and give long-term confidence in the brand Tüchel. We find that in the end sophisticated products are the best publicity!

All-round service – For us that's giving detailed technical advice to the customers before selling a product, briefing and training and a well-organized spare parts service, even many years after purchase and sale.

Be inspired by our products! Benefit from the wide range of attachments and enlarge your equipment pool!

Challenge us!

Yours sincerely
Your Dieter Beckmann

Table of Contents

TUCHEL-SWEEP

Road sweepers:

TUCHEL-SWEEP SIMPLEX	04
TUCHEL-SWEEP KOMPAKT	06
TUCHEL-SWEEP ECO	08
TUCHEL-SWEEP PLUS 590	10
TUCHEL-SWEEP PROFI 660	12
TUCHEL-SWEEP PROFI CHAMP	14
TUCHEL-SWEEP PROFI GIGANT	16
TUCHEL-SWEEP BIG	18
TUCHEL-SWEEP IDEAL	20
TUCHEL-SWEEP SOLO	22

TUCHEL-SNOW

Snow blades / Snow plows:

TUCHEL-SNOW L-SK	24
TUCHEL-SNOW SK-K	26
TUCHEL-SNOW SK-F	28
TUCHEL-SNOW L-SF	30
TUCHEL-SNOW SF	32
TUCHEL-SNOW VARIO	34

TUCHEL-TRAC

Vehicles:

TUCHEL-TRAC TRIO	36
TUCHEL-TRAC MINI 2	40
FARM-CLEAN	42
Technical data sheet: Brush shafts Brooms	44
Technical data sheet: Hydraulic connectors	45
Technical data sheet: A-frame	46
Technical data sheet: Three-point linkage	47
Contact	48
Notes	49

Cleanness is quite Simplex!

TUCHEL-SWEEP
SIMPLEX

For
fork-lifts,
tractors and
yard loaders



TUCHEL
MASCHINENBAU GmbH

Low weight – high performance!

The PTO-sweeper **SIMPLEX** has been designed for your small municipal tractor and front-mower in particular. The low weight of the **SIMPLEX** makes it the appropriate machine for front lifting-systems with a low lifting-capacity. The 100 % PP full bristle brush (Ø 400 mm) guarantees high durability. You can use the **SIMPLEX** for summer and winter service. Broom adjustment is done via the support-wheels. Standard equipment incl. levelling, pivoting part and mechanical angling. Basic equipment includes PTO-drive via PTO-shaft or hydraulic drive as an option.

Options

- Dirt collector, mechanical tip, incl. PU-lip
- Hydraulic tip of dirt collector
- Hydraulic drive of main brush
- Hydraulic angling
(1 additional double-acting hydraulic drive circuit required)
- Hydraulic side brush, fully adjustable, for corner sweeping
- Snow brush
- Splash guard for winter service
- Extra colour shade

Technical data		120	135	150
Working width (straight/angled)	cm	120/113	135/127	150/141
Brush ø	mm	400	400	400
Total width	cm	134	149	164
Weight simple sweeping*	kg	101	106	111
Weight incl. hopper*	kg	122	129	136
Fill capacity hopper	l	68	76	85

* incl. A-frame CAT communal

Measurements and weights are approx. and non-binding.

Hitch systems

- A-frame
- Three-point linkage
- Front mower hitch (direct mounting)



Simple sweeping



PTO-drive for
540 up to 2100 rpm



Side levelling



Hydraulic side brush

Cleanly „tucheled“!

TUCHEL-SWEEP KOMPAKT

For small
tractors, communal
vehicles & small
loaders!



TUCHEL
MASCHINENBAU GmbH

Clean sidewalks, squares and roads quite simply!

The **KOMPAKT** PTO-sweeper has been developed in particular for your compact tractor or communal vehicle. 100% PP brush discs in honeycomb shape (ø 520 mm) stand for high durability! The **KOMPAKT** can be used for summer and winter services. The user-friendly adjusting-lever allows a smooth adjustment of the brush. The basic configuration of this sweeper includes optionally PTO-drive via PTO-shaft or hydraulic drive. Another item of basic equipment is the mechanical angling. Whether simple sweeping or sweeping with hopper, the hopper does not have to be dismounted.

Options

- Large hopper incl. hydraulic tip, 3rd wheel and PU-lip (to avoid side-slip of stonelets)
- High-fill flap to increase fill-capacity of hopper (+ 30% approx.)
- PTO-shaft
- Hydraulic drive
- Mixed brush (50% wire / 50% PP) or snow brush
- Water-spray system assy., incl. water-pump and 100 l tank (for rear-mounting via three-point linkage)
- Hydraulic angling (1 additional double-acting hydraulic drive circuit required)
- Hydraulic side brush, adjustable (for corner sweeping)
- 3rd support-wheel incl. height adjustment, for simple sweeping
- Splash guard for winter service
- Reinforced wheels ø 200 x 50 mm for hard work
- Road traffic equipment (prescribed to drive on public roads)
- Extra colour shade

Technical data	135	150	175
Working width (straight / angled) cm	135/127	150/141	175/165
Brush ø mm	520	520	520
Total width cm	156	171	196
Required oil flow. (for 160 bar) l/min.	25	25	25
Weight simple sweeping* kg	185	192	203
Weight incl. hopper* kg	234	244	259
Fill capacity l	130	145	170

* incl. A-frame CAT communal

Measurements and weights are approx. and non-binding.

Hitch systems

- A-frame / three-point linkage incl. pendulum compensation
- Attachment for communal vehicles incl. pendulum compensation
- Yard loader attachment incl. levelling and pendulum compensation, incl. hydraulic drive and reinforced wheels



Side brush incl. speed adjustment



Double levelling incl. hydraulic angling



Adjusting-lever and parking stand



Simple sweeping mode (standard)

This road sweeper courts you!

TUCHEL-SWEEP
ECO

For tractors,
yard loaders
& fork-lifts!



TUCHEL
MASCHINENBAU GmbH

Quality for cost-conscious people!

The **ECO** has primarily been made for cost-conscious farmers who want a first-quality road sweeper. Thanks to multiple working widths this road sweeper cannot only be attached to tractors, but also to yard loaders and small fork-lifts. A variety of hitch systems guarantees an optimum fitment to your carrier-vehicle. Basic equipment incl. brand-named wheels with height adjustment, mechanical angling incl. shear-off bolts and a resistant PP-brush.

Options

- Hopper
- PU-lip on hopper as a protection against rabbles; is to avoid side-slip of stonelets
- Hydraulic tip
- 3rd support wheel for a regular bottom guidance
- Hydraulic angling (1 additional double-acting hydraulic drive circuit required)
- Heavy-duty wheels for hard work
- PTO-drive via PTO-shaft
- Hydraulic side brush for corner sweeping
- Extra colour shade

Technical data		150	180	230	260
Working width (straight/angled)	cm	150 / 141	180 / 169	230 / 216	260 / 244
Brush ø	mm	520	520	520	520
Total width	cm	185	215	260	290
Required oil flow (for 160 bar)	l/min.	25-30	25-30	30-40	30-40
Weight simple sweeping*	kg	194	205	225	237
Weight incl. hopper*	kg	264	283	316	336
Fill capacity	l	135	161	200	226

* incl. three-point linkage

Measurements and weights are approx. and non-binding.

Hitch systems

- Three-point linkage incl. parking stand
- Yard- and Front Loader attachment / Fork-tine system incl. parallelogram and pendulum compensation incl. height adjustment
- A-frame incl. pendulum adapter



Side brush and 3rd support-wheel



Hopper incl. PU-lip



Parallelogram



Levelling

A clear plus factor!

TUCHEL-SWEEP

PLUS 590

For tractors,
yard loaders,
communal vehicles
& fork-lifts



TUCHEL
MASCHINENBAU GmbH

...meeting any requirements.

This popular all-rounder really meets any requirements. Thanks to its variety of attachment systems and working widths the multi-purpose **PLUS 590** will be almost appropriate for all types of carrier-vehicles. The broom of the **PLUS 590** has been enlarged to 590 mm and is equipped with the unique 100% PP WaveLine mixture with CrownLock system, standing for high longevity and excellent sweeping results. The comfortable and easy approved broom adjusting-lever system guarantees optimal bottom guidance and the brand-new overrun control of the broom serves as a protection for the high-quality hydraulic components. Moreover, the entire series come with brand-named wheels ø 250 x 50 mm and parking stands. On demand, the **PLUS 590** can be equipped with a dirt collector incl. hydraulic emptying (standard). Standard equipment likewise includes a sophisticated broom positioning that assures an even distance between broom and dirt collector in order to always achieve the best possible sweeping-angle. The "simple sweeping" function has been entirely re-engineered, so as to enable the user to either work with the dirt collector or to use the **PLUS 590** for simple-sweeping without having to dismount the hopper.

Options

- Large hopper incl. PU-lip
- High-fill flap to increase fill capacity of hopper (+ 30% approx.)
- 3rd support-wheel for a regular bottom guidance
- Joint bearing (for three-point linkage / load relieving of 3rd wheel)
- Water-spray system to reduce dust, incl. 100 / 200 l tank and intermitting water-pump
- Levelling for a regular bottom guidance
- Hydraulic side brush for corner sweeping (water-spray system on option)
- Internal hydraulic motor (protected against damage)
- Oil flow controller > 90 liters
- Hydraulic angling (1 additional double-acting hydraulic drive circuit required)
- Reinforced wheels ø 250 x 80 mm for hard work
- Road traffic equipment (prescribed to drive on public roads)

Technical data		135	150	180
Working width (straight/angled)	cm	135/ 127	150/ 141	180/ 169
Brush ø	mm	590	590	590
Total width incl. motor* (external/internal)	cm	168/ 156	183/ 171	213/ 201
Required oil flow (for 160 bar)	l/min.	30	30	30
Weight simple sweeping	kg	264	274	294
Weight incl. hopper*	kg	329	344	373
Fill capacity	l	166	184	220

Technical data		200	230	260
Working width (straight/angled)	cm	200/ 188	230/ 216	260/ 244
Brush ø	mm	590	590	590
Total width incl. motor (external/internal)	cm	233/ 221	263/ 251	293/ 281
Required oil flow (for 160 bar)	l/min.	40	40	50
Weight simple sweeping*	kg	308	329	353
Weight incl. hopper*	kg	398	429	462
Fill capacity	l	244	280	315

* incl. yard loader hitch-system or three-point linkage

Measurements and weights are approx. and non-binding.

Hitch systems

- Three-point linkage for tractors
- A-frame, height adjustable incl. pendulum adapter
- Yard loader / Front loader attachment incl. parallelogram and pendulum compensation incl. height indicator
- Fork-tine attachment incl. parallelogram and height indicator
- Attachment system for communal vehicles incl. pendulum adapter
- Quick-hitch system for wheel loaders, incl. 3-D levelling and height indicator (up to 0,5m³ bucket capacity)
- Attachment plate for Unimog DIN 76060, size 3 and 5, incl. lifting cylinder, levelling and pendulum compensation



Side brush



Yard loader / Front loader attachment incl. parallelogram and pendulum compensation incl. height indicator



New levelling



The pro for „neat work“!

TUCHEL-SWEEP

PROFI 660

For
wheel loaders,
fork-lifts,
tractors &
Unimogs



TUCHEL
MASCHINENBAU GmbH

Your specialist for all applications!

The **PROFI 660** is the new generation of the well-known Tüchel sweeper machine series PROFIL. Its brush diameter is of 660 mm and the standard brush is equipped with a 100% PP WaveLine mixture in honey comb shape with CrownLock system as well as with a parking stand to protect the bristles. Additionally, an internal motor is part of the standard equipment. As an option, you can equip this sweeper with an enlarged dirt collector and choose between sweeping with hopper or simple sweeping (without dismounting the hopper). Furthermore, this machine is also equipped with the special Tüchel adjusting-lever system incl. an optimized sweeping-angle, which guarantee that the brush rings keep an uniform distance to the dirt collector in the event of wear and tear. In addition, the built-in after-running controller for the main brush protects the high-quality hydraulic components. The 3D levelling, being particularly developed for the **PROFI 660**, includes now a larger pendulum adapter, in order to balance floor unevenness in an optimal way.

Options

- Large hopper incl. PU-lip, high-fill flap (+ 30 % fill capacity), hydraulic tip and 3rd support-wheel for an equal bottom guidance
- Oil flow controller (> 90 liters / > 130 liters)
- Hydraulic angling (1 additional double-acting hydraulic drive circuit required)
- Splash guard for model without hopper; extra long, incl. PU-lip as protection against gravel
- Water-spray system against dispersion of dust, incl. 200 l water tank and dry running protective pump
- Hydraulic and adjustable side brush for corner sweeping, (water-spray system on option)
- Scraping device
- Road traffic equipment (prescribed to drive on public roads)
- Extra colour shade

Technical data		200	230	260	280
Working width (straight / angled)	cm	200/ 188	230/ 216	260/ 244	280/ 260
Brush ø	mm	660	660	660	660
Total width	cm	223	253	283	299
Required oil flow (for 160 bar)	l/min.	40	40	50	50
Weight simple sweeping*	kg	445	469	492	504
Weight incl. hopper*	kg	575	610	644	661
Fill capacity	l	315	361	407	431

* incl. quick-hitch system

Measurements and weights are approx. and non-binding.

Hitch systems

- Quick-hitch for wheel-/telescopic loaders, incl. 3D hitch system with roller floating tunnel, height indication and pendulum adapter
- Fork-tine attachment with quick-locking system; incl. 3D hitch system with roller floating tunnel, height indication and pendulum adapter
- Attachment plate for unimog DIN 76060, size 3 and 5, incl. lifting-cylinder, levelling and pendulum compensation
- A-frame or three-point linkage CAT I/II, incl. 3D hitch system with roller floating tunnel, height indication and pendulum adapter



100 % PP-Beeline Mixed brush ring system



Roller floating tunnel with height indication and pendulum adapter



Adjusting-lever system with optimized sweeping-angle



Side brush



The sweeping champion!

TUCHEL-SWEEP PROFI-CHAMP

For
big construction
machines, tractors
& Unimogs



TUCHEL
MASCHINENBAU GmbH

Sweeps sparkling clean!

The new **PROFI CHAMP**, with its internal hydraulic motor and the 750 mm broom is, due to the robust frame, the top-quality hydraulic components and the extra big wheels, suitable to even work under very difficult conditions on building sites. The standard brush is equipped with a 100% PP WaveLine mixture in honey-comb shape with CrownLock system. The special Tuchel adjusting-lever system with an optimized sweeping-angle ensures equal bottom guidance. In order to protect the hydraulic-components all technical details have been reworked and an after-running controller for the main brush has been integrated. The 3D levelling, being particularly developed for the **PROFI CHAMP**, includes now a larger pendulum adapter, in order to balance floor unevenness in an optimal way. The **PROFI CHAMP** can also be used for simple sweeping without dismounting the hopper.

Options

- Large hopper incl. PU-lip, high-fill flap (+ 30% fill capacity), hydraulic tip and 3rd support-wheel for an equal bottom guidance
- Oil flow controller (> 90 liters / > 130 liters)
- Hydraulic angling (1 additional double-acting hydraulic drive circuit required)
- Water-spray system incl. 200 / 400 liter tank and water pump with intermission function and protection against dry run
- Hydraulic side brush, adjustable, for corner sweeping (if desired with water-spraying device)
- Hydraulic side brush, incl. hydraulic lifting and lowering
- Hydraulic side brush, incl. hydraulic angling
- Scraper
- Road traffic equipment (prescribed to drive on public roads)
- Extra colour shade

Technical data		240	280
Working width (straight/angled)	cm	240/225	280/255
Brush ø	mm	750	750
Total width	cm	266	299
Hydraulic oil flow (at 160 bar)	l/min.	56	56
Weight simple sweeping*	kg	722	762
Weight incl. hopper*	kg	904	957
Fill capacity*	l	480	550

* with hitch-system for wheel loaders

Measurements and weights are approx. and non-binding.

Hitch systems

- Quick-hitch for wheel- / telescopic loaders, incl. 3D hitch system with roller floating tunnel, height indication and pendulum adapter
- Fork-tine attachment with quick-locking system; incl. 3D hitch system with roller floating tunnel, height indication and pendulum adapter
- Attachment plate for unimog DIN 76060, size 3 and 5, incl. lifting-cylinder, levelling and pendulum compensation
- A-frame or three-point linkage CAT I/II, incl. 3D hitch system with roller floating tunnel, height indication and pendulum adapter



Internal motor and optimized sweeping-angle



Hydraulic side brush w/hydraulic lifting and lowering



3D hitch system with roller floating tunnel



With scraper

Our heavy-weight champion!

TUCHEL-SWEEP PROFI-GIGANT

For big
construction
machines &
tractors



TUCHEL
MASCHINENBAU GmbH

This pro is a gigantic cleaner!

The **PROFI-GIGANT** road sweeper has been designed for the cleaning of extra large surfaces, airports, harbours, recycling companies, building-sites and industrial surfaces. With its very massive design it doesn't shy away from anything.

The hitch-pendulum joint protects the **PROFI-GIGANT** against overcharge by heavy carrier-vehicles and ensures an optimum bottom guidance. With its various working widths from 260 cm up to 350 cm and a brush diameter of 800 mm it cleans everything! The brush is driven by two strong, internal motors incl. oil flow controller. In order to facilitate brush adjustment, the machine has a special adjusting-lever system, which is to ensure that the brush wears down regularly.

The **PROFI-GIGANT** can be used with the hydraulic dirt collector or without, for simple sweeping (dirt collector doesn't have to be dismantled).

Options

- Hopper incl. PU-lip, high-fill flap, hydraulic tip (via 2 cylinders, incl. shut-off cock for simple sweeping) and integrated 3rd and 4th support-wheel
- Hydraulic angling via 2 cylinders (1 additional double-acting hydraulic drive circuit required)
- Water-spray system incl. 2 x 200 l tanks and intermitting pump for dust suppression
- Fully adjustable hydraulic side brush, speed adjustment and shut-off cock
- Road traffic equipment (prescribed to drive on public roads)
- Extra colour shade

Technical data	260	290	320	350
Working width (straight/angled) cm	260/ 236	290/ 263	320/ 290	350/ 317
Brush ø mm	800	800	800	800
Total width cm	286	325	355	385
Hydr. oil flow (at 160 bar) l/min.	100	100	100	100
Weight simple sweeping* kg	1357	1399	1443	1486
Weight incl. hopper* kg	1864	1932	2002	2071
Fill capacity l	760	850	935	1025

* incl. wheel loader hitch-system

Measurements and weights are approx. and non-binding.

Hitch systems

- Quick-hitch for wheel loaders incl. 3D levelling
- Three-point linkage CAT I/II incl. 3D levelling and height indicator



Ideal for terrain with rail traffic



2 strong internal drive motors



3D levelling ensures excellent bottom guidance



Easy brush adjustment by adjusting-lever system

Our BIG will succeed!

TUCHEL-SWEEP BIG

For
compact-
& wheel
loaders



You're flooded with dirt? No problem for our BIG!

The **BIG** bucket has particularly been designed for your compact-/ or wheel loader and is equipped as standard with a quick-hitch system. The machine is equipped with a large hopper and works totally different from ordinary road sweepers.

The brush is mounted in front of the debris collector, which looks like a bucket. Advantage: the weight of the swept material comes close to the carrier-vehicle and ensures an excellent distribution of weight, which is very important, if you work with compact and skid steer loaders.

Since the mounting point has been kept low, a good visibility for the driver is guaranteed. The resistant brush (100% PP, in honey-comb shape, Ø 600 mm) is easy to adjust and to exchange.

The **BIG** is driven by a strong hydraulic motor, incl. overload protection that is placed inside the shaft. Thus, it's well protected against any damage. A reinforcement kit makes your **BIG** the perfect machine for preparing hard standing areas for laying Tarmac.

Options

- Reinforcement kit for continuous operation: Anti-wear strip made from armour steel / screw-under knives in the bottom and on the side, double durability provided by simply turning the strip
- Mixed brush (50% PP / 50% wire)
- Fully adjustable hydraulic side brush (50% PP / 50% wire)
- Water-spray system with 100 / 200 l tank, incl. intermitting-pump and switch board for dust suppression
- Extra colour shade

Technical data		120	150	180	210
Working width	cm	120	150	180	210
Brush ø	mm	600	600	600	600
Total width	cm	147	177	207	237
Required oil flow (for 160 bar)	l/min.	25	40	40	50
Weight incl. hopper*	kg	354	398	447	495
Fill capacity	l	300	375	450	525

* without hitch system

Measurements and weights are approx. and non-binding.

Hitch systems

- Quick-hitch system for compact-/wheel loaders
- Compact loader adapter (different from Bobcat system)



BIG incl. quick-hitch system



Reinforcement kit for continuous operation



Water kit 100 l / 200 l for dust suppression



Fully adjustable hydraulic side brush (50% PP / 50% wire)

Sweeping without dusting!

For
fork-lifts
& wheel
loaders

TUCHEL-SWEEP
IDEAL 650



TUCHEL
MASCHINENBAU GmbH

Cleanness made to ideal measure!

The **IDEAL** road sweeper is in particular determined for industry and construction. It finds application in open areas, car parks and on building sites. Due to its dust-proof enclosure the Ideal road sweeper is the perfect machine to clean your buildings. The uncomplicated attachment system makes it fit your fork-lift or wheel loader in no time at all. The very robust machine includes a debris collector with hydraulic tip and assures high durability.

The specific floating brush is the heart of the **IDEAL** sweeper. The special brush in V-shape sweeps both, sticky and fine dirt and thus ensures an excellent sweeping result. The internal hydraulic motor is protected against damage and three support-wheels are to follow the ground contours.

Options

- Water-spray system with 100 / 200 l tank and intermitting-pump for dust suppression
- Fully adjustable hydraulic side brush
- Heavy-duty wheels ø 250 x 80 for hard work
- Road traffic equipment (prescribed to drive on public roads)
- Separate hydraulic aggregate incl. oil tank
- Extra colour shade

Technical data		130	150	180	210
Working width	cm	130	150	180	210
Brush ø	mm	650	650	650	650
Required oil flow	l/min.	25	25	25	30
Hydr. operating pressure	bar	160	160	160	160
Weight*	kg	455	479	516	556
Fill capacity hopper	l	210	240	290	335

* incl. fork-lift attachment

Measurements and weights are approx. and non-binding.

Hitch systems

- Fully floating hitch system (3D) for pallet tines
- Combined fully floating hitch system (3D) for pallet tines and wheeled loaders



Hitch system with 3D levelling (standard)



Hopper incl. hydraulic tip (standard)



Brush adjusting lever facilitates brush adjustment



Special V-brush for sticky and fine dirt

Ready, Steady, Go Sweeping!

For
fork-lifts,
tractors &
yard loaders

TUCHEL-SWEEP

SOLO



TUCHEL
MASCHINENBAU GmbH

Effective - Fast - Simple.

Have you already done all your sweeping work? With our new push broom **SOLO** out of the TUCHEL-SWEEP product range we can offer you a powerful alternative to ordinary sweeping. Our **SOLO** push broom is suitable for agriculture, construction, industry, forestry, plant & garden centres, horse keeping, landscape works and zoos. It ensures fast, effective, efficient and reliable cleaning and is appropriate to sweep coarse material, such as grain, corn silage, gravel, bark mulch, wood-chips etc.

Technical data		150	190	230	280
Working width	cm	150	190	230	280
Depth	cm	71	71	71	71
Brush rows	piece	11	11	11	11
Weight	kg	110	133	156	185

Measurements and weights are approx. and non-binding.

Hitch systems

- Fork-Tines
- Hitch system for shovels
- Three-point linkage
- Yard loader hitch



Shovel attachment



Three-point adapter



Yard loader hitch



Brush

Quickly free of snow...

For
small tractors,
yard loaders
& fork-lifts

TUCHEL-SNOW

L-SK



TUCHEL
MASCHINENBAU GmbH

... for little money.

Thanks to its various hitch-systems the **L-SK** snow blade can be easily attached to small tractors, yard loaders and fork-lifts and is even appropriate for the Tichel-Trac. Standard equipment includes spring flap segments, PU-lip (polyurethane), mechanical angling and height adjustable skids.

Options

- Hydraulic angling (1 additional double-acting hydraulic drive circuit required)
- Levelling
- Wheels (ø 150 x 50 mm)
- Road traffic equipment (warning flags & -holders, side-marker lamps LED)
- Colour option

Technical data		125	155	185
Total width	cm	125	155	185
Clearing width (in straight / angled position)	cm	125/ 107	155/ 133	185/ 160
Weight*	kg	84	97	110
Height	cm	50		
Angling	degree	up to 30		

* without hitch system

Measurements and weights are approx. and non-binding.

Hitch systems

- Three-point linkage
- A-frame
- Yard loader hitch incl. levelling and pendulum compensation system
- Fork-tine attachment

The main features at a glance:

- Interceptors on both sides included in standard equipment
- Spring flap segments (anti-icing)
- Optimum angle of inclination of the clearing lip, for perfect snow clearing
- Edge bending (side and top) ensures high stability of the snow blade
- Wheels instead of skids on option



Edge bending (side and top)



Spring flap segments (anti-icing)



Skids (wheels on option)



Hydraulic angling

The little snow master!

TUCHEL-SNOW
SK-K

For
small tractors,
yard loaders,
wheel loaders,
fork-lifts &
communal
vehicles



TUCHEL
MASCHINENBAU GmbH

Speedy snow clearing!

The stiff snow blade **SK-K**, incl. PU-lip (polyurethane) is appropriate in particular for clearing snow in the communal sector. The overrun protection makes the plough fold automatically, if it hits a barricade and thus protects it against any damage. With its various working widths it enables the user to clear walkways, small feeder roads and car parks very rapidly. Strong wheels instead of having skis are to avoid scraping on road carpets. Various hitch systems are to ensure an excellent adaptation to your carrier-vehicle. Basic equipment incl. mechanical angling to the left and right.

Options

- Hydraulic angling (1 additional double-acting hydraulic drive circuit required); on demand incl. pressure limit valve
- Extra stable, reinforced wheels (ø 200 x 50 mm)
- Road traffic equipment (warning flags & -holders, side-marker lamps LED)
- Colour option

Technical data		150	180	200	225
Total width	cm	150	180	200	225
Clearing width (in straight & angled position)	cm	150/ 132	180/ 159	200/ 176	225/ 198
Weight*	kg	186	213	223	235
Height	cm	70			
Angling	degree	up to 30			

* without hitch system

Measurements and weights are approx. and non-binding.

Hitch systems

- Three-point linkage
- A-frame
- Attachment plate for communal vehicles
- Fork-tine attachment
- Yard loader-/ wheel loader hitch incl. levelling (for small wheel loaders)

The main features at a glance:

- Interceptors on both sides included in standard equipment
- Optimum angle of inclination of the clearing lip, for perfect snow clearing
- Edge bending (side and top) ensures high stability of the snow blade



Hydraulic angling



Stable wheels



Edge bending (side and top)



Yard loader hitch
incl. levelling

A pro with spring flap segments!

TUCHEL-SNOW

SK-F

For
small tractors,
yard loaders,
wheel loaders,
fork-lifts
& communal
vehicles



TUCHEL
MASCHINENBAU GmbH

Free of snow in a flash

Standard equipment of the **SK-F** snow blade incl. anti-icing spring flap segments, PU-coated lip (polyurethane), mechanical angling and height adjustable wheels. On option, Tüchel offers a highly wear resistant communal- as well as a steel lip. The optimum angle of inclination ensures perfect and easy snow clearing. Edge bending (side and top) makes the **SK-F** even stronger and much more stable. Various hitch systems for small tractors, yard loaders, fork-lifts and small communal vehicles complete the **SK-F** snow blade. Interceptors (right/left) protect the machine against damage.

Technical data		150	180	200	225
Total width	cm	150	180	200	225
Clearing width (in straight & angled position)	cm	150/ 132	180/ 154	200/ 176	225/ 198
Weight*	kg	205	225	240	255
Height	cm	70			
Angling	degree	up to 30			

* without hitch system

Measurements and weights are approx. and non-binding.

Options

- Hydraulic angling (1 additional double-acting hydraulic drive circuit required); on demand incl. pressure limit valve
- Extra stable, reinforced wheels (ø 200 x 50 mm)
- Road traffic equipment (warning flags & -holders, side-marker lamps LED)
- Colour option

Hitch systems

- Three-point linkage
- A-frame
- Attachment plate for communal vehicles
- Fork-tine attachment
- Yard loader-/ wheel loader hitch incl. levelling (for small wheel loaders)

The main features at a glance:

- Interceptors on both sides included in standard equipment
- Spring flap segments (anti-icing)
- Optimum angle of inclination of the clearing lip, for perfect snow clearing
- Edge bending (side and top) ensures high stability of the snow blade



Wheels incl. infinitely variable height adjustment



Three-point attachment



Spring flap segments (anti-icing)



Edge bending (side and top)

A winter fairy tale!

TUCHEL-SNOW

L-SF

For
wheel- &
telescopic loaders,
tractors,
fork-lifts &
Unimogs



TUCHEL
MASCHINENBAU GmbH

Snow is marvellous...

...because the new **L-SF** helps you to clear snow effectively and easily. Standard equipment of the **L-SF** includes polyurethane coated spring segments. Moreover, Tüchel has optimised the angle of inclination to achieve a maximum possible quiet running of the snow blade. The anti-freezing spring segments allow a time-saving snow clearance, since there is no need of bothersome de-icing any longer. Reinforced protection caps on the right and left serve as a protection against shocks, to preserve the snow blade, if it encounters a badly visible obstacle under the snow cover. Basic equipment: mechanical angling towards the right and the left and very stable wheels avoid marks and scratches on the surfaces to be cleared.

Options

- Hydraulic angling (on demand incl. pressure limiting valve) 1 additional double-acting hydraulic drive circuit required
- Level compensation
- Extra stable wheels (250 x 80 mm)
- Plastic snow-guide cloth (for a good visibility for the driver)
- Road traffic equipment (flags,-holders, side-marker lights)
- Highly-resistant rubber lip w/corundum inlay for excellent sliding and long durability
- Colour options

Technical data		200	225	250	275	300
Width (straight/angled)	cm	210/ 181	235/ 203	260/ 224	285/ 245	310/ 267
Clearing width (straight/angled)	cm	200/ 173	225/ 194	250/ 215	275/ 237	300/ 258
Weight*	kg	367	392	417	437	462
Height	cm	82	82	82	82	82
Angling	degree	up to 30				

* without hitch system

Measurements and weights are approx. and non-binding.

Hitch systems

- Fully floating wheel loader/telly handler attachment incl. height indicators
- Three-point linkage (stiff attachment or fully floating) incl. height indicators
- A-frame (stiff attachment or fully floating) incl. height indicators
- Attachment plate for Unimog, size 3/5 incl. lifting-cylinder and level compensation for an optimum guide down to the ground floor
- Fork-tines for fork-lifts



Height indicators



Anti-icing spring flap segments (standard)



Parking stand



Infinitely height adjustable wheels



Various hitch systems available

The King of snow!

TUCHEL-SNOW

SF

For
wheel- /
telescopic loaders,
tractors, fork-lifts
& communal
vehicles



Take this and you'll do well!

Standard equipment of the **SF** snow blade includes spring flap segments, which assure a quick clearing of snow. The integrated protection system prevents the snow blade, if it strikes a barrier. The **SF** can be equipped with a PU-lip (polyurethane), a highly resistant communal lip, which guarantees long durability and excellent sliding qualities, as well as with a steel lip. Height adjustment of the clearing lip is done by the wheels. Heavy-duty wheels, in order to avoid marks on road surfaces, are available on option.

Options

- Hydraulic angling (1 additional double-acting hydraulic drive circuit required); on demand incl. pressure limit valve
- Pressure retention valve
- Skids
- CSE-wheels (heavy-duty) \varnothing 310 x 105 mm
- Snow-guide cloth (for a good visibility for the driver)
- Road traffic equipment (warning flags & -holders, side-marker lamps LED)
- Colour option

Technical data		250	275	300	325	350
Total width	cm	250	275	300	325	350
Clearing width (in straight & angled position)	cm	250/ 215	275/ 237	300/ 258	325/ 280	350/ 301
Weight*	kg	467	497	522	547	572
Height	cm	108				
Angling	degree	up to 30				

* without hitch system

Measurements and weights are approx. and non-binding.

Hitch systems

- Three-point linkage
- A-frame
- Attachment plate incl. lifting-device
- Fork-tine attachment
- Wheel loader- / tele handler hitch

The main features at a glance:

- Interceptors on both sides included in standard equipment
- Spring flap segments (anti-icing)
- Optimum angle of inclination of the clearing lip, for perfect snow clearing
- Edge bending (side and top) ensures high stability of the snow blade
- Reinforced pivoting-cylinders



Highly wear-resistant communal lip



Hitch systems for various carrier-vehicles available



Height adjustable wheels



Heavy-duty wheels

That runs like clockwork!

TUCHEL-SNOW

VARIO

For
small tractors,
Unimogs
& fork-lifts



TUCHEL
MASCHINENBAU GmbH

With this you'll get everywhere!

The **VARIO** snow plow is the ideal machine for a flexible clearing of snow. Hydraulic angling, secured by nitrogen bubbles, allows to use the two-part snow plow in V-, Y- and straight position. The PU-coated (polyurethane) spring flap segments provide security and protect the machine against damage. Height adjustable wheels assure clearing without leaving any marks on road surfaces. Various hitch systems allow a perfect attachment onto your carrier-vehicle.

Options

- Electro-magnetic switch for carrier-vehicles with one double-acting hydraulic drive circuit, only
- Level compensation
- Skids
- Extra strong wheels (200 x 80 mm, steel-welded - from 260 cm ø 310 x 105 mm)
- Road traffic equipment (warning flags & -holders, side-marker lamps LED)
- Colour option

Technical data	150	180	210	260	320	370
Clearing width in straight position cm	150	179	218	268	318	368
Clearing width in V-shape cm	135	161	199	226	273	281
Clearing width in Y-shape cm	135	160	193	222	257	320
Plow height middle/side cm	64/73	64/73	77/91	77/93	77/96	83/97
Angling rear/front degree	28/27	28/27	26/28	34/34	32/36	41/30
Weight* kg	254	278	362	435	518	598

* without hitch system, incl. PU-lip and pivoting part (levelling)

Measurements and weights are approx. and non-binding.

Hitch systems

- Three-point linkage
- A-frame
- Attachment plate incl. lifting-device
- Fork-tine attachment
- Yard loader-/wheel loader hitch incl. levelling (for small wheel loaders)

The main features at a glance:

- Spring flap segments (anti-icing)
- Optimum angle of inclination of the clearing lip, for perfect snow clearing
- Edge bending (side and top) ensures high stability of the snow plow
- Besides the PU-lip (polyurethane) a highly wear resistant lip incl. corundum inlay can be offered



Spring flap segments (anti-icing)



Hydraulic angling of the folding wings



Interceptors on both sides



VARIO incl. road traffic equipment (flags and lights)

The versatile all-rounder!

TUCHEL-TRAC®
TRIO

For
agriculture,
ground
maintenance,
horse farms...



TUCHEL
MASCHINENBAU GmbH

The versatile all-rounder!

Is it important for you to have a powerful, flexible and professional working tool that can be quickly mounted?

The **Tuchel-Trac TRIO** is the appropriate carrier-vehicle for you to let you minimize hard physical labour in agriculture, parks and landscaping, local authorities or in the building-industry. The compact design allows an entire overview from the driver's seat and short-way tool changes.

The all-wheel drive, the rear-steering shaft and the hydraulic steering characterise our three-wheeler. You can put the **Tuchel-Trac TRIO** to excellent work in different terrain and very tight spaces. The powerful hydraulic system ensures a fast and efficient work performance. The control levers of the working hydraulics are located conveniently directly beside the adjustable seat. A completely swivelling plastic engine cover gives easy access to the components for maintenance and service. With the **Tuchel-Trac TRIO**, you have an easy-to-operate, powerful vehicle.

Technical data		
Engine	kW (PS)	10,3 (14) at 3200 rpm
Hydraulic power	l/min	25 at 3200 rpm
Tank capacity (hydraulics)	l	65
Total width / turning radius	cm	92 / 146 (183)
Weight	kg	642 (operationally)

Measurements and weights are approx. and non-binding.

Options

- Additional double-acting hydraulic drive circuit
- Lawn tyres
- Rear weights
- Tow bar
- Rollover bar
- All-weather roof
- Working light
- Preheating system

Equipment:

- Kubota diesel engine
- All-wheel (hydraulic drive)
- Two driving speeds
- Hydraulic steering
- One double-acting drive circuit, one unpressurized return
- Quick-hitch system



TT-Trio with snow blade



Liquid manure scraper, even in the narrowest space



Passes most doorways



Economic working

Attachments for the stable work.

TUCHEL-TRAC®
TRIO

Number 1 in the domain of cow comfort: Cleaning of high-bed and deep-bed cubicles / slatted floors, bedding of straw and lime - all in only one operation!

Your advantages for stable maintenance:

- No more hard manual labour
- Time savings by the use of bedding spreader, manure scraper and / or food turner
- Clean, healthy cows on bedded rubber mats/deep-cubicle stalls (fewer udder infections)
- Saving of bedding material by appropriate dosage (chopped straw, sawdust, ground straw, lime-straw mixture)
- Immer saubere Spaltenböden mit dem Gülleschieber (weniger Klauenkrankheiten)
- Scraping on slatted floors and sweeping high-bed cubicle stalls in one go
- Driving on slatted floors with low load rating
- Mixing the fodder and pushing it towards the trough improves fodder ingestion of the cows
- Always a clean feed table

Bedding tool „E“ incl. agitator (automatic fill)

- Basic container: 450 liters, small top frame +170 l, big top frame +375
- Slurry scraper: working width 1450 mm
- Side brush ø 750 mm, or ø 850 mm mechanical adjustment via hand lever or hydraulic adjustment by hydraulic cylinder incl. tilting-device
- Infinitely variable speed of the agitator and the conveyor belt



Bedding tool „F“ incl. worm conveyor (manual fill)

- Basic container: 160 liters
- Slurry scraper: working width 1450 mm
- Side brush ø 750 mm or ø 850 mm mechanical adjustment via hand lever and hydraulic adjustment by hydraulic cylinder



Food turner

- Width 110 cm
- Pivot-mounted on both sides
- Cleaning lip behind the worm-type food turner



Manure scraper with double lip

- Width max. 130 cm, adjustable, height 35 cm
- On option: hydraulic side brush, adjustable



Mixing of fodder – satisfied cows



Optimal claw health by clean slatted floors



Cleaning slatted floors - high-bed and deep-bed cubicles - and bedding - all at once!



Bedding tool „E“ incl. parking stand

For farm work.

TUCHEL-TRAC® TRIO

The TUCHEL-TRAC TRIO simplifies your farm work:

Farm maintenance and landscape conservation. Your advantages:

- Clean farm yards, parks, cemeteries, riding compounds, pavements...
- Easy cleaning of corners and hard-to-reach areas by using the side brush or radial brush
- Snow-free yard driveways, pavements and other paths and squares
- Well-groomed path edges and lawns with rotary/mulching mower

Sweeping-machine

- Working width: 120 cm
- Brush ø 400 mm, 100 % PP-Bristles
- Hopper, mechanical emptying
- Hydraulic emptying / angling
- Side brush (hydraulic), 100% PP



Radial broom

- Operating width 120 cm
- Hydraulic drive via two motors



Rotary-mulching mower

- Operating width 120 cm
- Hydraulic drive via two motors



Snow blade

- Operating width 125 cm
- Hydraulic angling, on option



Road sweeper



TRIO with various attachments



Rotary-mulching mower

Small - Compact - Flexible.

TUCHEL-TRAC MINI 2

For the
maintenance of
stables &
properties



TUCHEL
MASCHINENBAU GmbH

A true vehicle miracle!

Small, compact, flexible and fast, that's our new **MINI 2**. Standard equipment includes hydrostatic front-wheel drive. By means of the rear steering axle the **MINI 2** has got a turning radius of only 490 mm. Thanks to the quick-hitch system, the mounting and dismounting of many tools is particularly user-friendly. Thus, many jobs around your farm can be done comfortably and quickly.

The main features at a glance:

- Hour meter
- Splash-proof ignition lock
- Robust steering, mechanically via gear ring and steering linkage
- Quick-hitch
(Exchange of tools from driver's position possible)
- Tool-less seat adjustment
- Easy accessible engine for maximum ease of maintenance
- Clearly arranged controls
- Steering wheel with integrated steering knob
- Ergonomically shaped foot pedal for the traction drive
- Self-tightening V-belt for the traction drive
- Comfortable getting on and dismounting from the vehicle

Technical data		MINI 2 M
Dimensions (without tool)	mm	width: 830 x length: 1680 x height: 1260
Motor / Capacity		Briggs & Stratton Series 950E 4,9 kW (6,6 HP / 3600 rpm) E-Starter and reversing starter
Drive		hydrostatic front-wheel drive via V-belt
Lifting system		mechanical
Hydraulic drive circuits		---
Weight	kg	225
Turn radius (inside)	mm	490

Technical data		MINI 2 H
Dimensions (without tool)	mm	width: 830 x length: 1680 x height: 1260
Motor / Capacity		Honda GXV 340 6,6 kW (9 HP / 3600 rpm) E-Starter and reversing starter
Drive		hydrostatic front-wheel drive via V-belt
Lifting system		hydraulic
Hydraulic drive circuits		1 x double-acting (9,8 l / 180 bar)
Weight	kg	280
Turn radius (inside)	mm	490

Measurements and weights are approx. and non-binding.

Options:

- Slurry scraper 105 cm, V-shaped, wear-resistant PU-double-lips (polyurethane)
- Slurry scraper 105 cm (as described above) incl. side brush ø 600 mm, 100% PP, hydraulically swiveling, height is mechanically adjustable (only for H)
- Fodder push blade / snow blade 135 cm, right and left swiveling, incl. wear-resistant clearing lip; to lay fodder and to clean the feed table simultaneously, applicable also for snow clearance
- Fodder push blade / snow blade 135 cm (equipment as described above) incl. hydraulic lateral adjustment (only for H)
- Radial brush 105 cm, 100% PP, hydraulic, clockwise / anti-clockwise rotation (only for H)
- Radial brush 105 cm (equipment as described above) incl. deflector plate, for a thorough cleaning of the feed alley (only for H)



Parking brake



Clearly arranged controls



Quick-hitch



Ergonomically shaped foot pedal for the traction drive

Pushing - Sweeping - Scraping!

TUCHEL-TOOL
FARM-CLEAN

For
house
& farm



TUCHEL
MASCHINENBAU GmbH

Handy, efficient and powerful!

A stable rod steering and big field tyres ensure a great performance. Basic equipment incl. hydraulic drive and hydraulic connections for further attachments, which can be tool-free mounted or dismounted.

Technical data	
Engine	Honda gasoline engine, 5,5 HP
Wheel drive	hydraulic forward / backwards
Speed regulation steps	1 (incl. infinitely variable speed adjustment on enquiry)
Total weight	680 mm (for manure scraper)
Hydraulic connections	1 x double-acting

Options

- **Infinitely variable traction drive**, up to 3,7 km/h
- **Extra broad field tyres**
- **Manure scraper**, V-shape, 100 cm / height 20 cm, type double-lip, incl. level compensation, fully galvanized, incl. ammoniac-resistant wear lip – ensures a quick and simple cleaning of slatted floors, even in tight spaces.
- **Fodder blade**, 110 cm / height 40 cm, angling right/left, incl. level compensation, powder-coated, incl. highly resistant lip to push the fodder back to the trough and to clean the feed alleys.
- **Snow blade**, 95 cm, height 40 cm, angling right/left, incl. resistant wear lip, incl. levelling, powder-coated.
- **Axial sweeper**, 75 cm, hydraulic drive, brush diameter 320 mm, powder-coated, angling right / left, incl. levelling
- **Dirt collector**, 75 cm, powder-coated, suitable for axial sweeping-machine, incl. scraper lip.
- **Radial sweeper**, ø 80 cm, powder-coated, hydraulically driven, incl. right/left run.



Double-lip manure scraper incl. levelling and interceptors



Fodder blade

Various mounting possibilities and applications



Hitch system and double-acting hydraulic connector, standard



Height adjustable guiding-rod incl. forward/backwards gear

Brush shafts / Brooms

Brush shafts - Product type overview

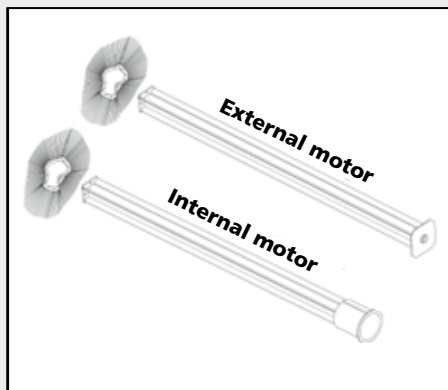

Brush shafts for brush elements

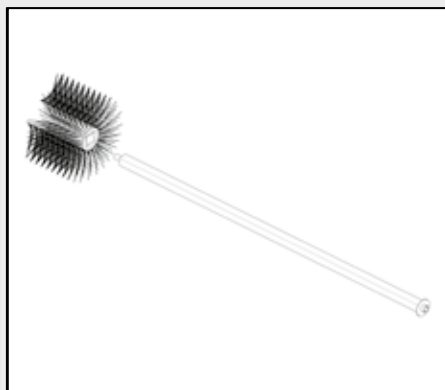

Brush shafts for brush segments

Brooms - Product type overview

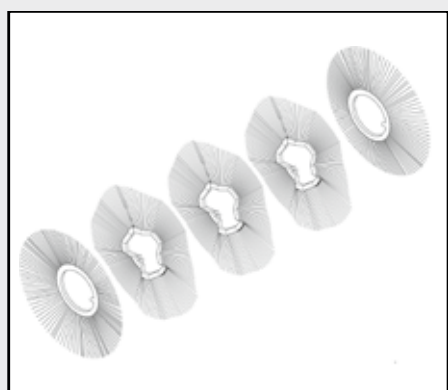

Beeline

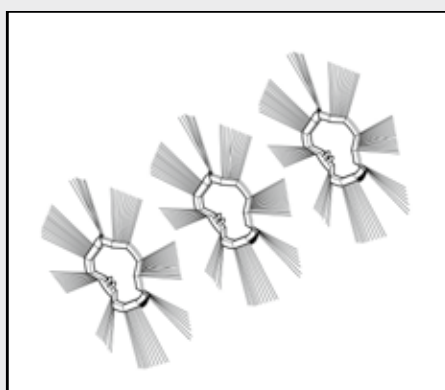

Snowline

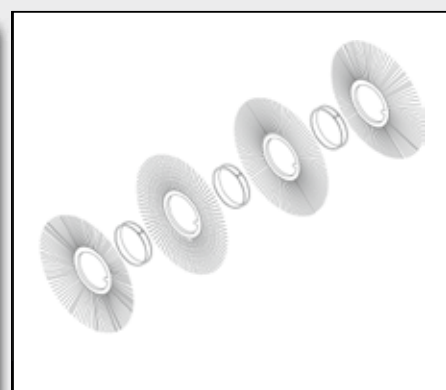

Sunline or
Sunline / Wire



Brush segments

Hydraulic connectors

SVK-connector - (Size 3 = standard, further types on enquiry)

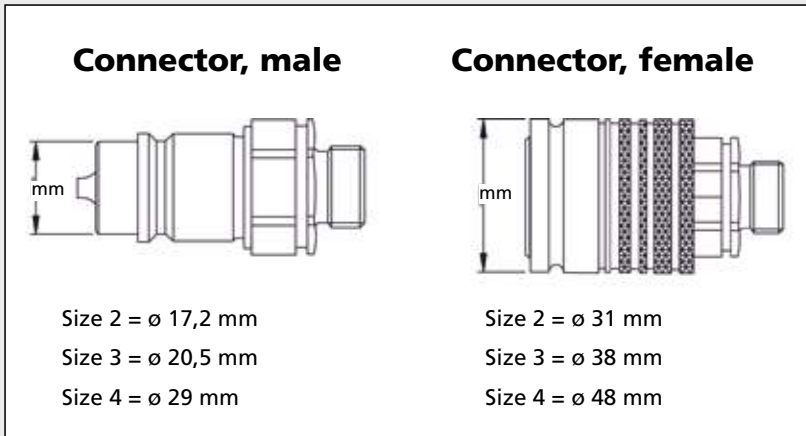

Screw coupling

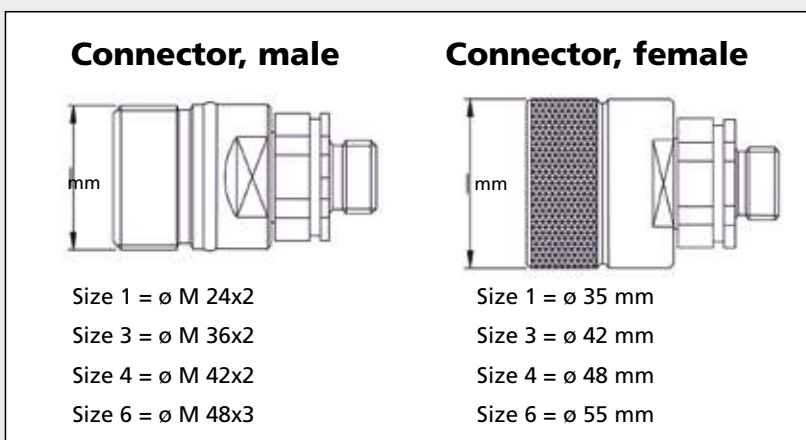

Flat-Face connector - (non drip)

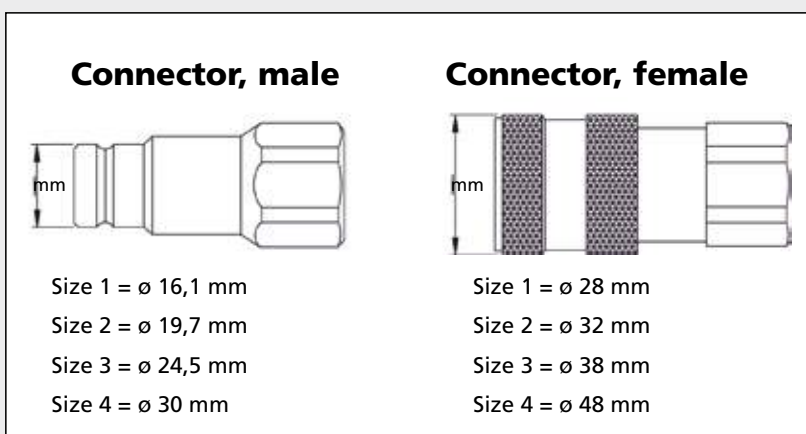

A-frame

A-frame acc. to ISO 11001-2

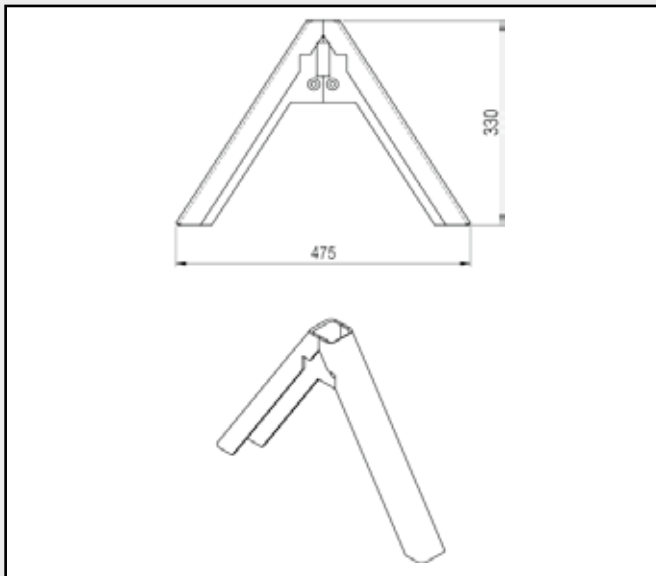

A-frame: CAT Communal

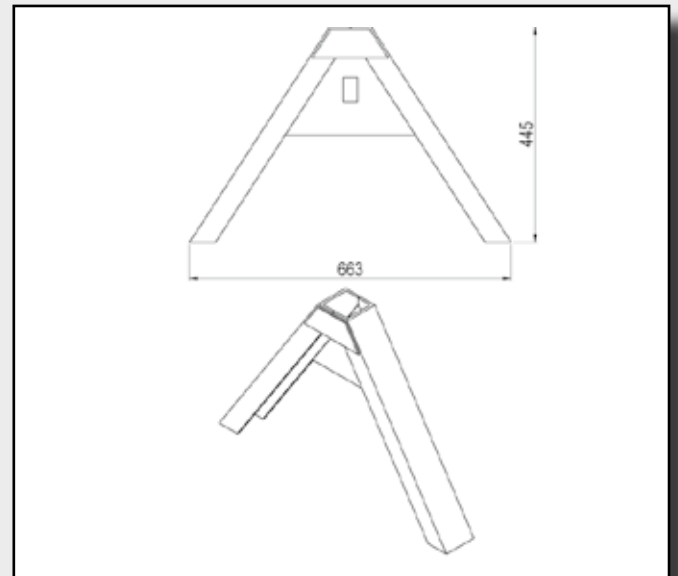

A-frame: CAT 0

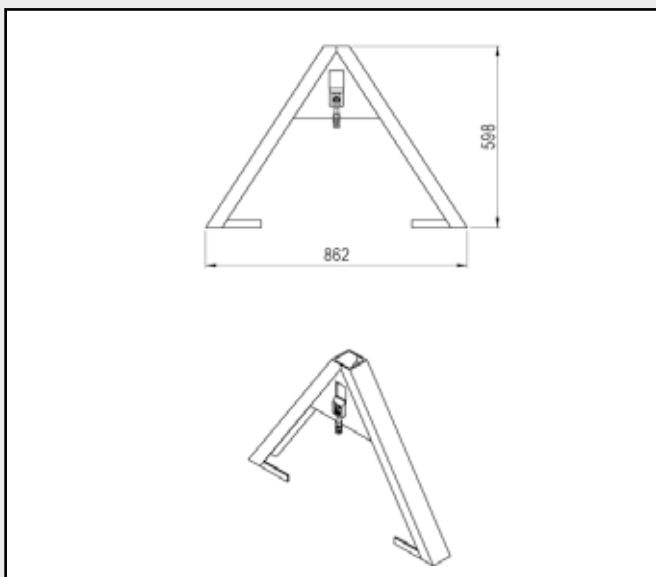

A-frame: CAT 1

Special sizes on enquiry: Errors and omissions excepted.

Three-point linkage

Three-point linkages acc. to DIN ISO 730-1

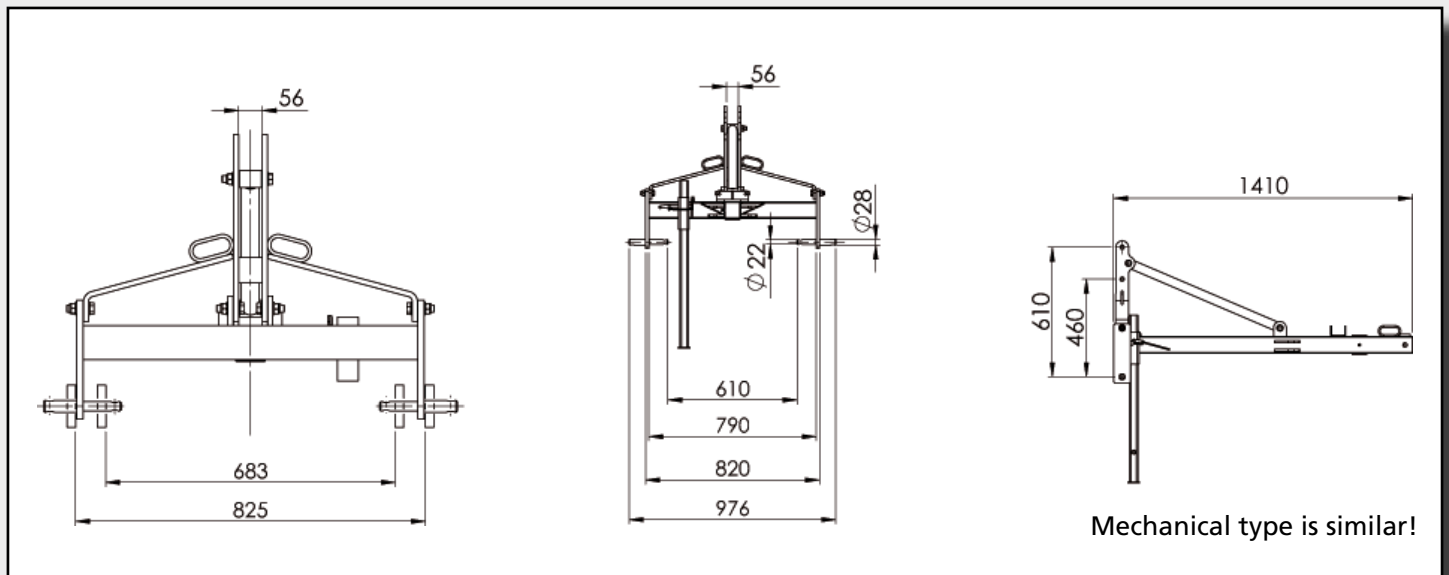

Three-point linkage CAT I / II

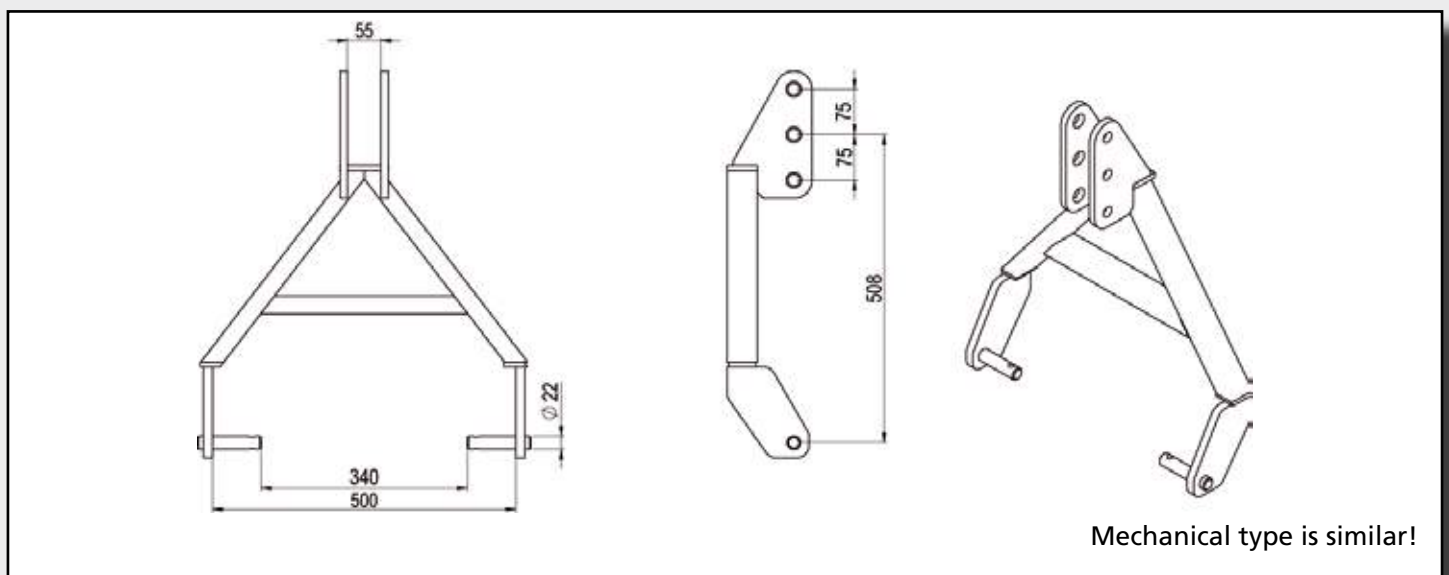

Three-point linkage CAT I N

Special sizes on enquiry: Errors and omissions excepted.

Export Sales Team

Feel free to contact us!



Ksenia Kelsch

k.kelsch@tuchel.com
(+49) 05971 - 9675-39



Eckhard Rahe

e.rahe@tuchel.com
(+49) 05971 9675-15
Mobile: (+49) 0162 2354033
Mobile: (+49) 0151 61309446



Quality „made in Germany“!

Tuchel Maschinenbau GmbH – the inventor among the experts.

Again and again, working machines and attachments from Tuchel set a course in the domain of agriculture and building-machines. In our modern factory in Salzbergen our highly-qualified staff manufacture more than 3.000 machines per year. Whether road sweepers, snow blades, hand-operated machines or multifunctional all-wheel-drive vehicles: Tuchel counts on quality and only uses high-quality components, such as eg. motors from Sauer Danfoss. That's another good reason for making Tuchel to your reliable business partner!

**Ask for
information
now!**

+49 (0) 59 71 9675-0



Tuchel usually delivers their machinery with standard hydraulic connectors. Special hydraulic connectors on demand, only!
Measurements, weights and technical data are non-binding and prior to change.

Your Tuchel-partner:



03/2016_10012901

Tuchel Maschinenbau GmbH · Holsterfeld 15 · 48499 Salzbergen · Germany
Phone: +49 (0) 59 71 96 75-0 · Fax: +49 (0) 59 71 96 75-30 · E-mail: export@tuchel.com · www.tuchel.com