



- > Disc Chippers
- > Stump Grinders
- > Drum Chippers



THE POWER TO PERFORM >



# Quality and Tradition

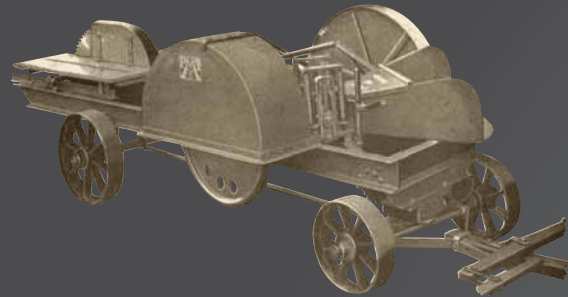

1884

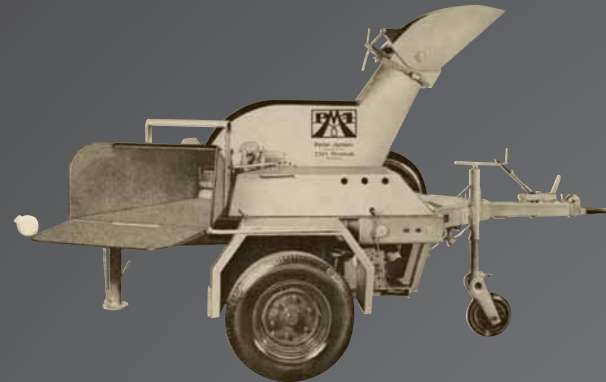

2014

**We have what you are looking for.**

**Efficient, reliable and long-lasting - JENSEN Machines stand for quality right across the line.**

With more than 130 years of experience in the development and production of wood chippers, our diverse range of products will enable you to find what you are looking for. Make JENSEN your favourite brand among wood chippers.

Convince yourself of the highest quality "Made in Germany", robust design with superior performance and excellent service.

**THESE IMAGES ARE JUST A FEW OF THE SPECIALS JENSEN HAS BUILT FOR SPECIFIC CLIENTS.**

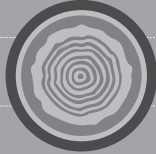

# Table of Contents

	Trunk Diameter	Page
Foreword		02
Index		03
Overview Engine Machines		04 - 05
A530	130 - 150 mm	06
A540	190 mm	07
A425	200 mm	08
A328	220 mm	09
A231	240 mm	10
A141 XL	300 mm	11
Overview PTO Chippers		12 - 13
Overview Tracked Chippers		14 - 15
A540 Spider	190 mm	16
Technical Specifications		17
Technical Specifications		18 - 19
Drum Chippers	400 - 550 mm	20 - 21
Stump Grinders SCX50D		22
Stump Grinders SCX70D		23



## Powerful Diesel Engine

Choose between two well known engine brands, the water-cooled Kubota engine or the air-cooled Hatz engine. Both brands are available with various levels of power perfectly attuned to meet your requirements.



## Infeed Hopper

According to your needs, you can choose between a fixed or a compact, fold down feed hopper. Both come equipped with a safety bar. Depending on the infeed control, it is used as a control bar or as an emergency stop bar.



## Touch Button Feed Control

JENSEN offers two options for feed control. The manual hydraulic system to remove electrics completely or illuminated touch pad rated feed controls to remove any possibility of water and vibration issues related to electrics.

This option offers maximum safety and is very user friendly.

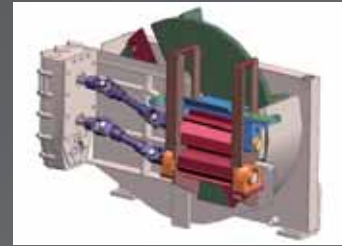

## Intermeshing Feed Roller System

Designed to grip and take away the most awkward material. Twin horizontal feed rollers are timed through a precision gearbox which allow the rollers to lock together for maximum grip on small brashy material as well as large timber. The conventional chipper has a motor powering each feed roller - the JENSEN has one motor which means the power to each roller is consistently strong whatever the material.



## Auto Overload Regulator

All JENSEN machines can be delivered with an auto overload regulator. This electric device monitors the speed of the flywheel preventing the timber from feeding on to the flywheel when the flywheel rotations fall below a preset level. This allows the engine and flywheel to build up speed again before the rollers are re engaged to continue the chipping process.

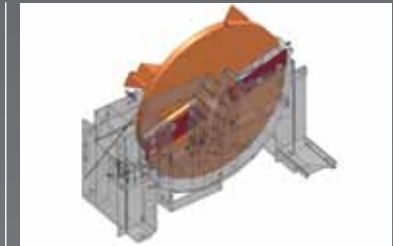

## Open Flywheel System

The flywheel is the heart of every wood chipper. Two blades which cut the full width of the timber mounted on a large flywheel with open tops means there is nothing to hinder the chip leaving the flywheel. Four full width draught fins pick up the material and throw it out of the chamber rather than relying on air to blow the chip. This means clearing green, wet material is simply not a problem and blockages are virtually unheard of.

# Unique Points of Saling (UPS) Engine Machines



## Chipper Blades

The chipping blades can be resharpened and feature a double edge for optimal cutting conditions and very good chip quality. The chopping blades are also supported on the cutting disc for extreme loads. Installation or replacement is a simple process.



## Simple to remove Anvil

A definite edge on the anvil (bed knife) is just as important as it is to have sharp blades. A worn anvil will put substantial stress on the machine. The JENSEN anvil takes only 5 minutes to change. A small cover and a 1 clamp bolt are all that are needed to be removed to allow you to remove the anvil with a slide hammer. The anvil is double sided for maximum efficiency.



## Double Disc Comb System

For high quality wood chips there is a special double disc available with a comb system. After the blades have cut the timber the rotating flywheel throws the bigger chips to the chipping frame where they are crushed into smaller pieces between the fingers of the comb system. The size and quality of the chips are suitable for heating and energy systems. The double comb system is available for the model A425 and bigger.



## Ruggedly designed Machineries

JENSEN stands for robust design that meets the requirements of harsh field conditions. The use of steel for almost all components, from the feeding and cutting through to the chassis up to the panel has proved successful, time and time again. The machines are designed to endure shock, impact and heavy loads. It increases longevity and is thus a clear sign of quality.



## Committed to high Requirements

Our machines meet the current standards and requirements according to DIN EN 13525. Our feed hoppers are manufactured to CE standard. When selecting our suppliers we ensure the highest quality. We exclusively use components from leading manufacturers.



## Operation and Service

Simplicity is the key! For all maintenance works, optimal conditions were created to ensure cost-effectiveness. It does not get much faster to maintain a machine.

130 mm  
150 mm



# A530

**A bestseller  
for years.**



The A530 - compact and handy, is available in three different versions.

The smallest version has an infeed roller aperture of 210 x 130 mm, whereas the A530 L and the A530 XL infeed roller measures 210 x 150 mm - all machines are equipped with powerful diesel engines.

The A530 L is a lightweight version of the A530 with a weight of max. 750 kg.

Made for driving licence class B without entitlement.

With it's high level of user and maintenance friendliness, high performance and reliability makes the model A530 a favourite among our customers.

## Technical Specifications

Technical details and illustrations reserved for further developments.

	A530	A530 L	A530 XL
Infeed Roller Aperture	210 x 130 mm	210 x 150 mm	210 x 150 mm
Feed Hopper Width x Height	860 x 740 mm	850 x 830 mm	860 x 740 mm
Engine (Diesel)	Kubota 16,8 kW (22 hp)	Kubota 26 kW (35 hp)	Kubota 27,2 kW (37 hp)
Flywheel Dimensions	600 x 25 mm	600 x 25 mm	600 x 25 mm
Flywheel Weight	70 kg	70 kg	70 kg
Number of Blades	2	2	2
Output (approx)	12 m <sup>3</sup> /hr	15 m <sup>3</sup> /hr	15 m <sup>3</sup> /hr
Length x Width x Height	3.400 x 1.350 x 2.150 mm	3.400 x 1.350 x 2.150 mm	3.400 x 1.350 x 2.150 mm
Approx Weight	750 kg unbraked	730 kg unbraked	900 kg
(Depending on the model)	800 kg braked	750 kg braked	

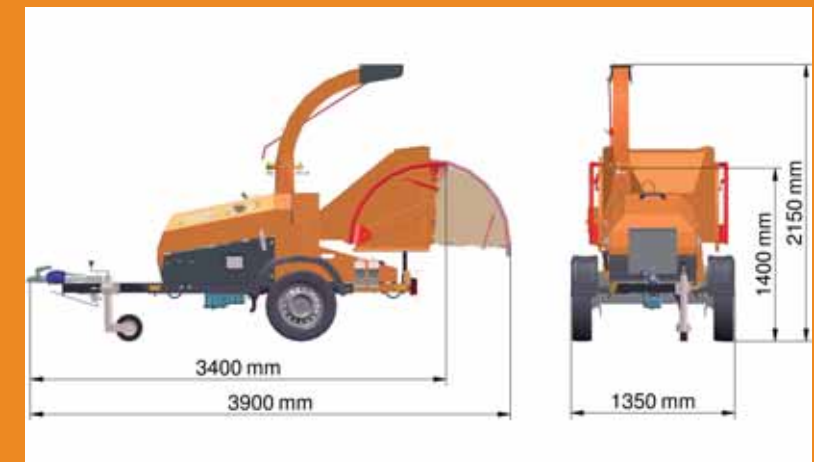

With its new design our top seller, the JENSEN A540, shines among the small model series.

Completely modified it is more versatile and user friendly. With this machine you can chip up to 190mm timber thanks to the strength and power of the JENSEN feed roller system. The key features are the wide hopper, huge flywheel, strong feed roller grip and big bearings. The model comes with an integral toolbox mounted in the service center for convenient tool storage.

If you work mainly on the highway the perfect solution is the A540 Turntable. This machine shares all features and qualities of the A540 but sits on a 270° turntable chassis.

With the engine mounted to the side of the chipping chamber rather than the front to back making the machine ideal for city work.

With the hopper at the rear of the machine in transport position no adjustments need to be made if you don't need to work from the side.

All panels and guards fold out simply and easily for routine maintenance and blade changes.



Turntable

# A540

[www.jensen-service.de](http://www.jensen-service.de)



## A perfect All-rounder!



### Technical Specifications

Technical details and illustrations reserved for further developments.

	A540	A540 Turntable
Infeed Roller Aperture	210 x 190 mm	210 x 190 mm
Feed Hopper Width x Height	1.000 x 800 mm	1.000 x 800 mm
Engine (Diesel)	Kubota 27,2 kW (37 hp)	Kubota 27,2 kW (37 hp)
Flywheel Dimensions	650 x 30 mm	650 x 30 mm
Flywheel Weight	120 kg	120 kg
Number of Blades	2	2
Output (approx)	18 m <sup>3</sup> /hr	18 m <sup>3</sup> /hr
Length x Width x Height	3.400 x 1.500 x 2.400 mm	3.500 x 1.800 x 2.550 mm
Approx Weight (Depending on the model)	1.200 kg	1.450 kg

200 mm



# A425

## A Machine that raises no questions



Like all JENSEN machines, the A425 is known for its robustness, excellent functionality, user friendliness and the highest level of safety.

Optional is the A425 with a complete rotation on a single or twin axle chassis.

With the flexibility of the turntable of 270° the A425 is an asset for anyone who relies on it, on busy streets chip material is quickly processed. The loading of the machine can be done from either side.

This ensures the safety of its operators.

### Technical Specifications

Technical details and illustrations reserved for further developments.

	A425	A425 Turntable
Infeed Roller Aperture	245 x 200 mm	245 x 200 mm
Feed Hopper Width x Height	1.050 x 880 mm	1.050 x 880 mm
Engine (Diesel)	Kubota 36 kW (50 hp)	Hatz Silent 24,0 kW (33 hp) or 36,2 kW (50 hp) / Hatz 24,3 kW (33 hp) or 36,8 kW (50 hp) / Kubota 36 kW (50 hp)
Flywheel Dimensions	730 x 30 mm	730 x 30 mm
Flywheel Weight	150 kg	150 kg
Number of Blades	2	2
Output (approx)	20 m <sup>3</sup> /hr	20 m <sup>3</sup> /hr
Length x Width x Height	4.200 x 1.800 x 2.600 mm	3.700 x 2.000 x 2.800 mm
Approx Weight (Depending on the model)	1.500 kg	1.800 kg

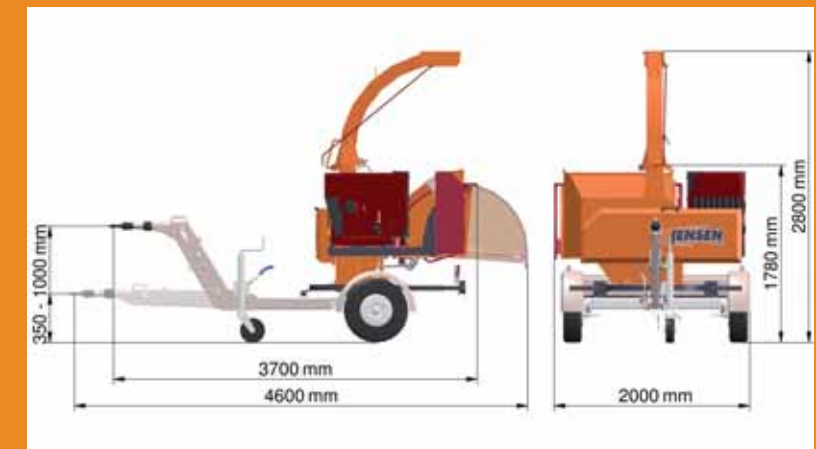



With its 180 kg heavy chipping disc and its 330 mm wide blades, the A328 guarantees a high chipping performance.

It's solid feed rollers handle bush and stem wood up to 220mm in diameter with ease. If you require a high powered machine for grinding large quantities of wood, the A328 is the right choice for you.

The A328 is available with a turntable on a single or twin axle chassis. With the mobility of the 270° turntable, the A328 is an asset for anyone who relies on processing large volumes of chip material on busy streets quick problemfree.

The machine can be loaded from any side, so that the safety of operators is always taken into consideration.

The A328 convinces with its service ability. With just a few quick and easy steps maintenance is easily executed.

# A328

## Designed to convince

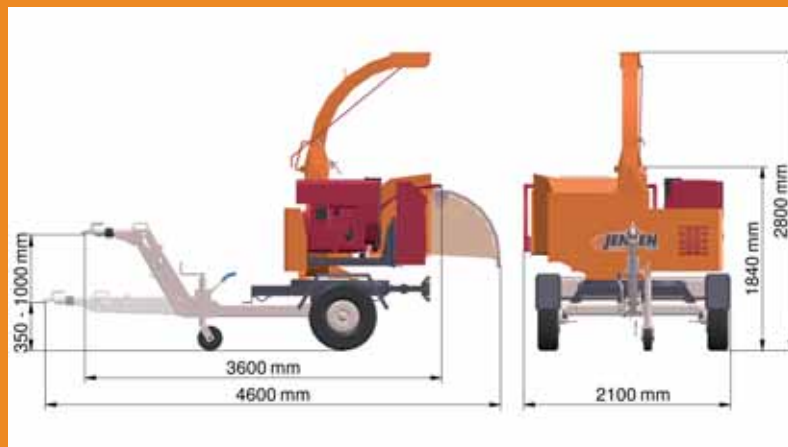

### Technical Specifications

Technical details and illustrations reserved for further developments.

	A328	A328 Turntable
Infeed Roller Aperture	280 x 220 mm	280 x 220 mm
Feed Hopper Width x Height	1.150 x 800 mm	1.150 x 800 mm
Engine (Diesel)	Kubota 50 kW (68 hp)	Hatz Silent 36,2 kW (50 hp) or 47,7 kW (65 hp) / Hatz 36,8 kW (50 hp) or 50,6 kW (69 hp) / Kubota 50 kW (68 hp)
Flywheel Dimensions	820 x 35 mm	820 x 35 mm
Flywheel Weight	180 kg	180 kg
Number of Blades	2	2
Output (approx)	25 m <sup>3</sup> /hr	25 m <sup>3</sup> /hr
Length x Width x Height	4.000 x 1.800 x 2.500 mm	3.600 x 2.100 x 2.800 mm
Approx Weight (Depending on the model)	1.800 kg	2.100 kg

240 mm



# A231

## Compact and powerful !



As JENSENS's second largest wood chipper among the disc chippers, the A231 convinces with reliability and power.

With a chipping capacity of 30m<sup>3</sup>/hr this machine is already a winner.

You can choose between four Hatz diesel engines meeting your specific demands. Special requests are also possible with this model.

Tell us your wish, we will fulfill it!

### Technical Specifications

Technical details and illustrations reserved for further developments.

Infeed Roller Aperture	310 x 240 mm
Feed Hopper Width x Height	1.160 x 800 mm
Engine (Diesel)	Hatz Silent 36,2 kW ( 50 hp) or 47,7 kW (65 hp) / Hatz 36,8 kW (50 hp) or 50,6 kW (69 hp)
Flywheel Dimensions	970 x 35 mm
Flywheel Weight	250 kg
Number of Blades	2
Output (approx)	30 m <sup>3</sup> /hr
Length x Width x Height	4.300 x 2.300 x 3.100 mm
Approx Weight (Depending on the model)	2.500 - 2.650 kg

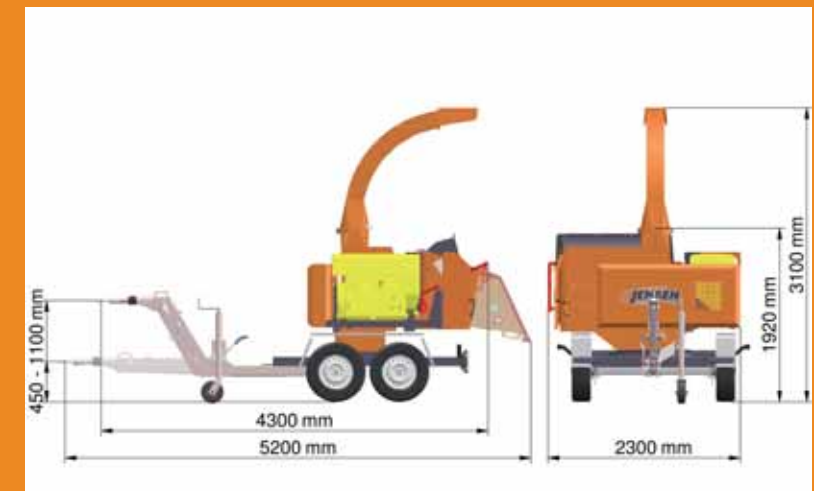

The JENSEN A141 XL, with an engine and a turntable, mounted on a twin chassis is designed for chipping up to a trunk diameter of 300 mm.

With its enormous power, it creates a chipping capacity of approximately 35 m<sup>3</sup> / hour and is considered as the largest disc chipper from the JENSEN range.

The A141 XL is available with a Hatz engine with 47.7 kW ( 65 hp ), as a Silent model, or with 50.6 kW (69 hp).

We would be pleased to meet your special requests (crane, container, conveyer belt and much more).

# A141 XL

**Power and  
perfection.**

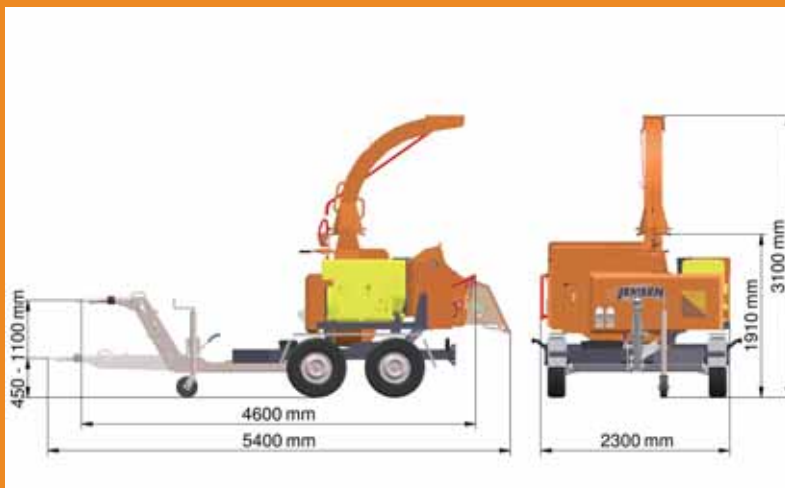

## Technical Specifications

Technical details and illustrations reserved for further developments.

Infeed Roller Aperture	410 x 300 mm
Feed Hopper Width x Height	1.370 x 840 mm
Engine (Diesel)	Hatz Silent 47,7 kW (65 hp) / Hatz 50,6 kW (69 hp)
Flywheel Dimensions	1.060 x 40 mm
Flywheel Weight	270 kg
Number of Blades	2
Output (approx)	35 m <sup>3</sup> /hr
Length x Width x Height	4.600 x 2.300 x 3.100 mm
Approx Weight (Depending on the model)	3.000 - 3.200 kg

# PTO Chippers

**Robust, powerful and compact -  
The JENSEN PTO chippers are alternatives  
for users with tractors or other vehicles.**

All JENSEN machines are completely self contained with their own hydraulic system. They only need drive and electrical supply from the power unit to work.

Right through the range, the JENSEN PTO machines boast outstanding performance and reliability.

The smallest model A530 can already be operated with a compact tractor starting at 22 kW (30 hp) over the PTO drive power.

The power requirement increases according to the model ranging up to 60 kW (82 hp).

Either as rear or front mount units and with the option of manual or crane feed hoppers there will be a JENSEN machine to meet your needs.

Cranes as well as chassis and other extras can also be mounted and supplied with the machine.



	<b>A530 PTO</b>	<b>A530 XL PTO</b>
Infeed Roller Aperture	210 x 130 mm	210 x 150 mm
Feed Hopper Width x Height	860 x 740 mm	860 x 740 mm
Flywheel Dimensions	600 x 25 mm	600 x 25 mm
Flywheel Weight	70 kg	70 kg
Number of Blades	2	2
Output (approx)	12 m <sup>3</sup> /hr	15 12 m <sup>3</sup> /hr
Length x Width x Height	1.850 x 1.150 x 2.400 mm	1.850 x 1.150 x 2.400 mm
Approx Weight	500 kg	500 kg
Power Requirements	22 kW (30 hp)	22 kW (30 hp)

	<b>A540 PTO</b>
Infeed Roller Aperture	210 x 190 mm
Feed Hopper Width x Height	1.000 x 800 mm
Flywheel Dimensions	650 x 30 mm
Flywheel Weight	120 kg
Number of Blades	2
Output (approx)	18 m <sup>3</sup> /hr
Length x Width x Height	1.700 x 1.230 x 2.400 mm
Approx Weight	750 kg
Power Requirements	30 kW (40 hp)

	<b>A425 PTO</b>
Infeed Roller Aperture	245 x 200 mm
Feed Hopper Width x Height	1.050 x 880 mm
Flywheel Dimensions	730 x 30 mm
Flywheel Weight	150 kg
Number of Blades	2
Output (approx)	20 m <sup>3</sup> /hr
Length x Width x Height	1.800 x 1.200 x 2.400 mm
Approx Weight	800 kg
Power Requirements	40 kW (55 hp)

	<b>A328 PTO</b>
Infeed Roller Aperture	280 x 220 mm
Feed Hopper Width x Height	1.050 x 800 mm
Flywheel Dimensions	820 x 35 mm
Flywheel Weight	180 kg
Number of Blades	2
Output (approx)	25 m <sup>3</sup> /hr
Length x Width x Height	2.100 x 1.400 x 2.700 mm
Approx Weight	900 kg
Power Requirements	50 kW (68 hp)

	<b>A231 PTO</b>
Infeed Roller Aperture	310 x 240 mm
Feed Hopper Width x Height	1.160 x 800 mm
Flywheel Dimensions	970 x 35 mm
Flywheel Weight	250 kg
Number of Blades	2
Output (approx)	30 m <sup>3</sup> /hr
Length x Width x Height	1.900 x 1.500 x 2.900 mm
Approx Weight	1.400 kg
Power Requirements	55 kW (75 hp)

	<b>A141 XL PTO</b>
Infeed Roller Aperture	410 x 300 mm
Feed Hopper Width x Height	1.370 x 840 mm
Flywheel Dimensions	1.060 x 40 mm
Flywheel Weight	270 kg
Number of Blades	2
Output (approx)	35 m <sup>3</sup> /hr
Length x Width x Height	2.150 x 1.600 x 2.900 mm
Approx Weight	1.900 kg
Power Requirements	60 kW (82 hp)

# Tracked Chippers

**Go anywhere - chip anything !**

Time is money! It is important to rely on your working equipment and to be as flexible as possible. JENSEN keeps you on the front line and allow you to achieve a high performance and reliability. Investing in a high quality machine pays off quickly. What you will gain is excellent build quality, outstanding functionality and a professional partner for your fleet.

With our stable and powerful tracked wood chippers you can work in places that are difficult to access. Whether it's railways, highway embankments or difficult and steep terrain, you will navigate through with ease. With this mobile machine you can reach a speed of approx 3 km/h and overcome slopes up to 30°.

For our tracked wood chippers we offer an additional rail track security package which allows the machine to be left on site in remote areas. It includes lockable diesel and hydraulic filler caps, a lockable cover on the control panel and bonnet, and an extra tool box for securing chains and locks etc. It also includes an earth switch and securing eyes to allow the machine to be secured to an immovable object.



## Choose between different track systems:

Our range of tracked chippers can be fitted with fixed or variable track system. For both models A530XL and 540, JENSEN offers a tilt bed system for light embankment work.

In addition to the rigid design of the tracked wood chipper, we also offer a track system which is hydraulically adjustable.

This version is perfectly compatible with a **system for level compensation/ tilt bed**. If you require a dedicated embankment machine then the JENSEN spider track system offers unrivalled stability and access to banks.

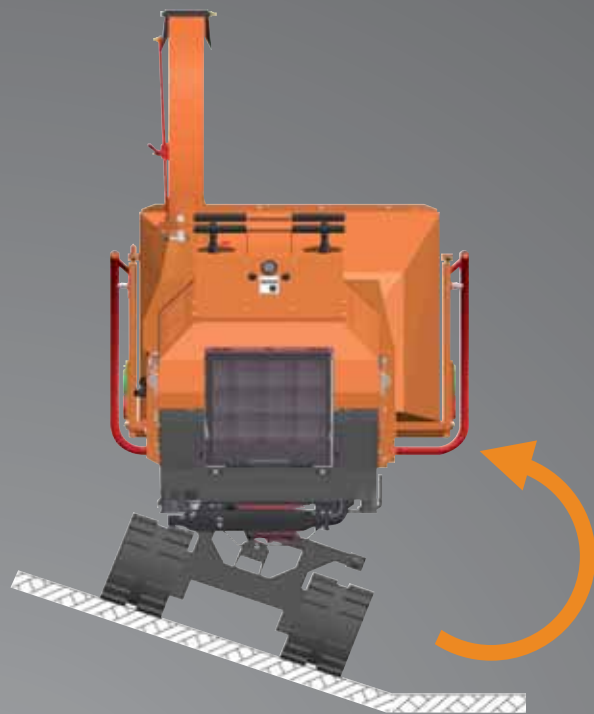

System for Level Compensation / Tilt bed

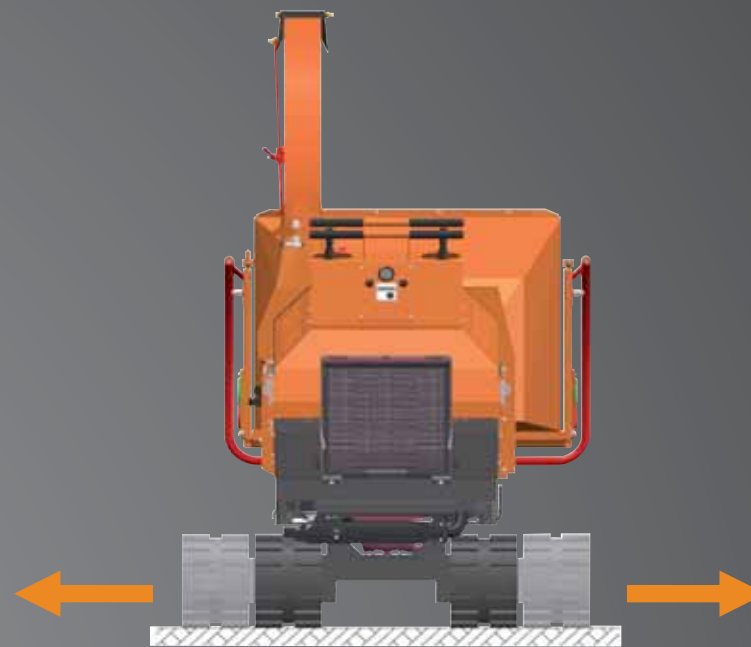

Adjustable tracks

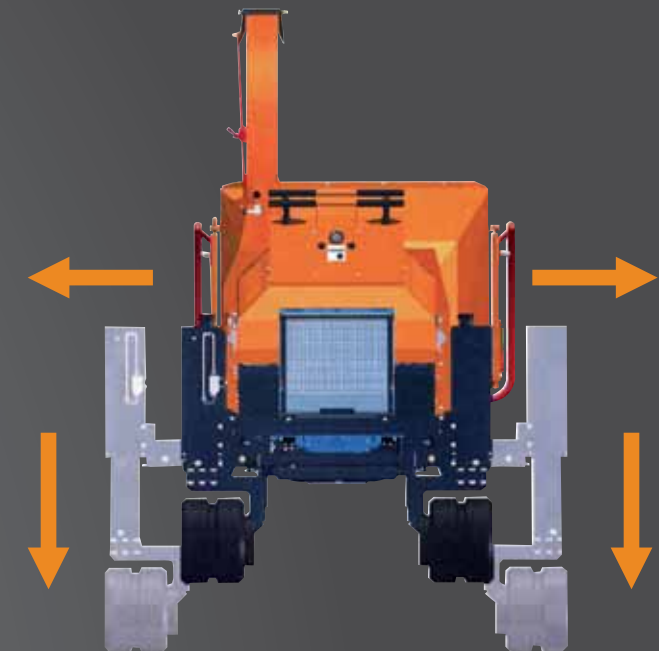

Spider track system

190 mm



# A540 Spider

## Exceptional Ground Clearance



The all new embankment and awkward terrain chipper from JENSEN. This machine really is fantastic and is something to admire in its agility, compact size and manoeuvrability. Superb stability on the bank side twinned with the ability to control tracks vertically and horizontally means this machine is the most versatile machine of its type on the market.

Exceptional ground clearance when the tracks are either in or out means this machine doesn't have to be wide when it needs height. High speed tracking is a huge benefit when accessing your worksite and a 50 hp Kubota behind the trusted and proven chipping system means performance is just brilliant.

Unrivalled performance when handling and grappling awkward material and exceptional chip clearance. This is a robust and reliable, true contractors tool.

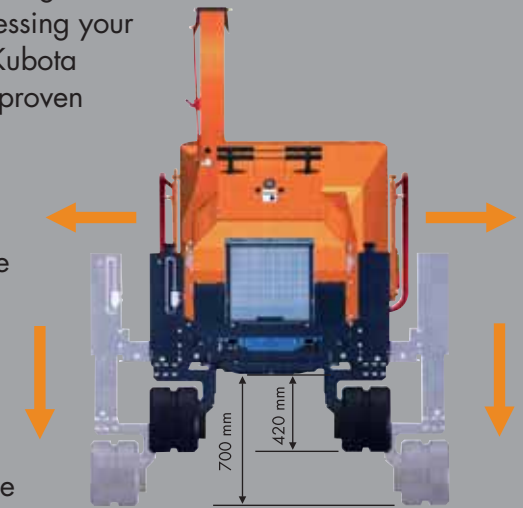

A540 Spider

## Technical Specifications

Technical details and illustrations reserved for further developments.

Infeed Roller Aperture	210 x 190 mm
Feed Hopper Width x Height	1.000 x 800 mm
Engine (Diesel)	Kubota 27 kW (37 hp) or 36 kW (50 hp)
Chipping Disc Dimensions	650 x 30 mm
Chipping Disc Weight	120 kg
Number of Blades	2
Output (approx)	18 m <sup>3</sup> /hr
Length x Width x Height Chassis Retracted	2.400 x 1.315 x 2.500 mm
Length x Width x Height Chassis Extended	2.400 x 1.820 x 2.800 mm
Approx Weight (depending on the model)	1.900 kg

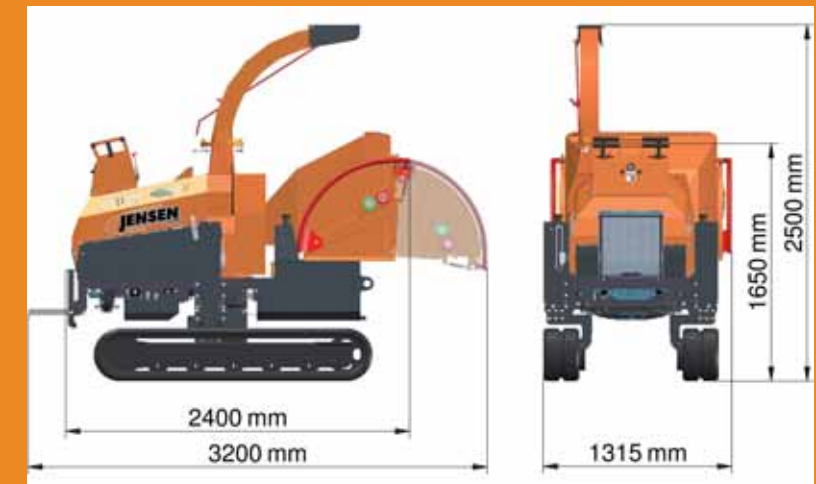



# Move with the time!

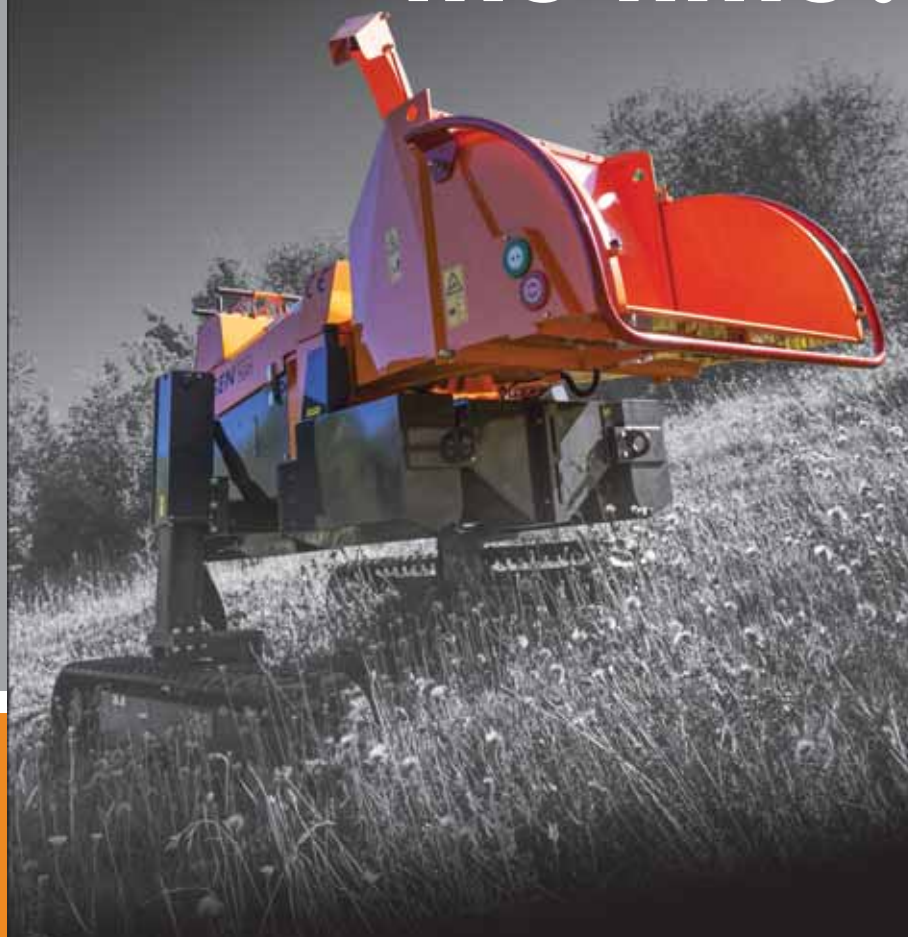

A425



A328



A530 XL



A540

JENSEN provides you with an individual offer.

## Technical Specifications

	Tracked A425	Tracked A328	Tracked A530 XL	Tracked A540
Infeed Roller Aperture	245 x 200 mm	280 x 220 mm	210 x 150 mm	210 x 190 mm
Feed Hopper Width x Height	1.050 x 880 mm	1.150 x 800 mm	860 x 740 mm	1.000 x 800 mm
Engine (Diesel)	36 kW (50 hp)	50 kW (68 hp)	27 kW (37 hp)	27 kW (37 hp) / 36 kW (50 hp)
Length x Width x Height fixed track system	3.300 x 1.400 x 2.790 mm	3.400 x 1.400 x 2.800 mm	2.920 x 1.200 x 2.700 mm	2.950 x 1.200 x 2.700 mm
Length x Width x Height variable track system	3.300 x 900 - 1.300 x 2.790 mm	3.400 x 1.200 - 1.620 x 2.800 mm	2.920 x 780 - 1.160 x 2.700 mm	2.950 x 900 - 1.400 x 2.700 mm
Approx Weight fixed / variable	2.200 / 2.300 kg	2.300 / 2.400 kg	1.200 / 1.250 kg	1.400 / 1.450 kg

Technical details and illustrations reserved for further developments.

Type	A530	A530 L	A 530 XL	A540	A425	A328	A231	A141 XL
<b>Basic chipping unit</b>								
Capacity ø (mm)	130	150	150	190	200	220	240	300
Feed roller aperture w x h (mm)	210 x 130	210 x 150	210 x 150	210 x 190	245 x 200	280 x 220	310 x 240	410 x 300
ø Flywheel (mm)	600	600	600	650	730	820	970	1.060
Thickness flywheel (mm)	25	25	25	30	30	35	35	40
Weight flywheel (kg)	70	70	70	120	150	180	250	270
Capacity (m <sup>3</sup> /h)	12	15	15	18	20	25	30	35
Infeed system	Oil motor/ gear box	Oil motor/ gear box	Oil motor/ gear box	Oil motor/ gear box	Oil motor/ gear box	Oil motor/ gear box	Oil motor/ gear box	Oil motor/ gear box
Hopper dimensions w x h (mm)	860 x 740	850 x 830	860 x 740	1.000 x 800	1.050 x 880	1.150 x 800	1.160 x 800	1.370 x 840
Chipping length, hydraulic adjustable (mm)	5 - 20	5 - 20	5 - 20	5 - 20	5 - 20	5 - 20	5 - 20	5 - 20
<b>Engine machines</b>								
Engine	KUBOTA	KUBOTA	KUBOTA	KUBOTA	KUBOTA / HATZ	KUBOTA / HATZ	HATZ	HATZ
Engine power (diesel) kW (hp)	16,8 (22)	26,0 (35)	27,2 (37)	27,2 (37)	24,0 (33) - 36,8 (50)	36,2 (50) - 50,6 (69)	36,2 (50) - 50,6 (69)	47,7 (65) - 50,6 (69)
Wheeled chassis 80 km/h	Single axle	Single axle	Single axle	Single axle/ tandem axle	Single axle/ tandem axle	Single axle/ tandem axle	Single axle/ tandem axle	Single axle/ tandem axle
Dimensions l x w (mm)	3.400 x 1.350	3.400 x 1.350	3.400 x 1.350	3.400 x 1.500 / 3.500 x 1.800	4.200 x 1.800 / 3.700 x 2.000	4.000 x 1.800 / 3.600 x 2.100	4.300 x 2.300	4.600 x 2.300
Height with chute (mm)	2.150	2.150	2.150	2.400 / 2.550	2.600 / 2.800	2500 / 2.800	3.100	3.100
Weight appr. (kg)	750 unbraked 800 braked	730 unbraked 750 braked	900	1.200 / 1.450	1.500 / 1.800	1.800 / 2.100	2.500 - 2.650	3.000 - 3.200
Machine on turntable	-	-	-	- / 270°	- / 270°	- / 270°	- / 270°	- / 270°

Type	A530	A530 L	A 530 XL	A540	A425	A328	A231	A141 XL
<b>PTO machines</b>								
Dimensions l x w (mm)	1.850 x 1.150	-	1.850 x 1.150	1.700 x 1.230	1.800 x 1.200	2.100 x 1.400	1.900 x 1.500	2.150 x 1.600
Height with chute (mm)	2.400	-	2.400	2.500	2.400	2.700	2.900	2.900
Weight appr. (kg)	500	-	500	750	800	900	1.400	1.900
Wheeled chassis 25 of 80 km/h	Single axle	-	Single axle	Single axle	Single axle	Single axle	Single axle	Single axle
Dimensions machine on wheeled chassis (mm)	2.500 x 1.400	-	2.500 x 1.400	3.200 x 1.600	3.200 x 1.600	3.200 x 1.700	3.400 x 1.800	3.400 x 1.900
Height with chute on wheeled chassis (mm)	2.600	-	2.600	2.600	2.600	2.800	3.000	3.000
Weight with wheeled chassis appr. (kg)	700	-	700	900	1.000	1.200	1.800	2.100
Machine on turntable	-	-	-	-	2 x 90°	2 x 90°	2 x 90°	2 x 90°
<b>Tracked machines with fixed tracks</b>								
Length (mm)	-	-	2.920	2.950	3.300	3.400	on demand	on demand
Width (mm)	-	-	1.200	1.200	1.400	1.400	on demand	on demand
Height (mm)	-	-	2.700	2.700	2.790	2.800	on demand	on demand
Weight appr. (kg)	-	-	1.200	1.400	2.200	2.300	on demand	on demand
<b>Tracked machine with variable tracks</b>								
Engine	-	-	KUBOTA	KUBOTA	KUBOTA	KUBOTA	on demand	on demand
Engine power (diesel) kW (hp)	-	-	27,2 (37)	27,2 (37) - 36 (50)	36 (50)	50 (68)	on demand	on demand
Length (mm)	-	-	2.920	2.950	3.300	3.400	on demand	on demand
Width (mm)	-	-	780/1.160	900/1.400	900/1.300	1.400	on demand	on demand
Height (mm)	-	-	2.700	2.700	2.790	2.800	on demand	on demand
Weight appr. (kg)	-	-	1.250	1.450	2.300	2.400	2.900	3.200
Speed appr.	-	-	3 km/h	3 km/h	3 km/h	3 km/h	3 km/h	3 km/h

Technical details and illustrations reserved for further developments.

400 mm



# Drum Chipper JT 600

Made for contractors who want maximum chipping power and quality.



The drum chipper JT600 is the most compact machine of its class. The above-average flywheel mass of this chipper guarantees the simple processing of timber with a diameter of up to 400mm.

The PTO power requirements with this machine are at least 65 kW (88 hp) - compared to the larger model of this series, the JT600 can be operated with smaller tractors.

Another difference to the TJ Models is in the electronic infeed control where a Siemens SP is used in the auto overload regulator.

The regular JT600 comes with a conveyor belt of 1000 mm in length.

Optionally the JT600 can be fitted with a conveyor belt of 2300 mm in length.

Get your individual offer!



JT600 equipped with crane.



Rotor diameter 600 mm with 6 chipping blades and large flywheel.



JT600 equipped with a conveyor belt of 2300 mm and a crane.



JENSEN offers a range of drum chippers, which are driven either by the tractor via drive shaft or independently with its own diesel engine. The JT600 can process stem and bush wood with a height of 400 mm and width of up to 600 mm while the TJ1250 can accommodate stem and bushwood with a height of up to 550 mm and width of up to 1250 mm. The use of high quality materials and components and robust construction ensure reliable and long-term use in the toughest working conditions. The rotors of the large model series are connected via a v-belt clutch with the drive. This improves power transfer and reduces the risk to damage the drive components. With the JT600's v-belt drive a clutch was not implemented since the PTO connection of the traction unit allows the engine to run smoothly. The design of the rotor in open form allows the quick ejection of the chips and thus increases the overall performance of the machine. The blades of the rotor and the anvil can be replaced easily. As a result the machine is quickly serviceable. All functions of the machine can be monitored and programmed via the display of the CAN controller. Through the use of different screens and the independent adjustment of the feed speed the size of the chips can be easily adjusted. If you're struggling to find the ideal tool for your application, contact us today to discuss your requirements.



[www.jensen-service.de](http://www.jensen-service.de)



## Technical Specifications

	JT600	TJ850	TJ1050	TJ1250
Infeed Roller Aperture	560 x 400 mm	800 x 620 mm	1.000 x 620 mm	1.200 x 620 mm
Feed Hopper Width	1.330 mm fixed with conveyor belt 2.000 mm foldable with convey belt	1.875 mm	2.075 mm	2.275 mm
Rotor Diameter		820 mm (open)	820 mm (open)	820 mm (open)
Number of Blades	2	8 / 16	10 / 20	12 / 24
Wood Diameter	400 mm	350 mm hardwood 450 mm softwood and bushes	400 mm hardwood 500 mm softwood and bushes	450 hardwood 550 mm softwood and bushes
PTO Power Requirements min.	65 kW (88 hp)	185 kW (250 hp)	225 kW (300 hp)	260 kW (350 hp)
Engine Power	110 kW (150 hp)	Depending on the model	Depending on the model	Depending on the model
Screen Size Width x Height	40 x 40 / 50 x 50 / 60 x 60 / 80 x 80 / 100 x 100 mm	40 x 40 / 60 x 60 / 80 x 80 / 100 x 100 mm	40 x 40 / 60 x 60 / 80 x 80 / 100 x 100 mm	40 x 40 / 60 x 60 / 80 x 80 / 100 x 100 mm
Chassis for PTO Machine	One-Axe/ Tandem 25, 40 or 80 km/h	Tandem 40 oder 80 km/h	Tandem 40 oder 80 km/h	Tandem 40 oder 80 km/h
Chassis for Engine Machine	Tandem 80 km/h	Tandem 80 km/h	Tandem 80 km/h	Tandem 80 km/h
Crane	optional	optional	optional	optional
Remote Control	optional	optional	optional	optional
Length x Width x Heigh with Crane	4.950 x 2.500 x 3.250 mm	5.600 x 2.450 x 3.850 mm	5.650 x 2.500 x 3.850 mm	8.580 x 2.530 x 3.850 mm
Approx Weight (depending on the model)	6.200 kg	12.500 kg	13.500 kg	14.620 kg

Technical details and illustrations reserved for further developments.

# SCX50D

360  
mm  
400



# JENSEN Stump

## Very compact and versatile

With its robust and compact design stands the equally impressive JENSEN stump grinders. A fully hydraulic machine on a hydraulically adjustable tracked machine is completely radio remote controlled.

The cutting area of the SCX50D is approx 360mm over and 400mm under the planum and the SCX70D is approx 300 mm over and 580mm under the planum. With a swing arc of 1.650mm the cutter wheels have the capacity to process large root stocks.

The unique Multi Tip cutter wheel system allows the JENSEN root stump grinders to achieve optimum cutting depth with even force distribution and guarantees simple and easy maintenance.

### Technical Specifications

Technical details and illustrations reserved for further developments.

Engine (Diesel)	Hatz Silent 36,2 kW (50 hp)	Diesel Engine Tank Capacity	approx 60 L
Track Width Retracted approx	780 mm	Hydraulic Tank Capacity	approx 85 L
Track Width Extended approx	1.170 mm	Cutter Wheel Diameter	568 mm
Driving Speed	approx 4 km/h	Cutter Wheel Strength	20 mm
Length x Height	3.200 x 1.350 mm	Number of Cutting Teeth	8
Approx Weight	1.800 kg	Cutter Wheel Swing arc	1.650 mm
		Workdepth under Planum	400 mm
		Workdepth over Planum	360 mm



# Grinders

## Increased Performance

The combination of more cutting tips on a wheel whilst maintaining a good distance between the teeth, packs a punch that is unmatched by any other system.

## Quick to change

An single bolt holds the tooth in place. This is undone and tightened with a simple hex key.

## Cost Saving

The tooth takes nearly all the wear because all the other components are protected.

## Strength

Forces are transferred directly into the wheel with very little bending or shearing action on any components.

## Ease

Teeth can only be fitted one way, there is no special adjustment necessary. Ensuring perfect setup every time.



Cutter Wheel



Cutting Tooth

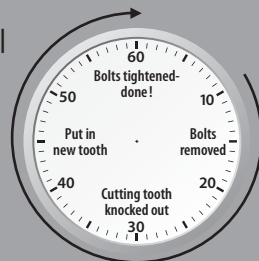

Changing the cutting tooth in 60 sec.

# SCX70D

[www.jensen-service.de](http://www.jensen-service.de)

300  
mm  
580



## Technical Specifications

Technical details and illustrations reserved for further developments.

Engine (Diesel)	Hatz Silent 47,7 kW (64 hp)	Diesel Engine Tank Capacity	approx 60 L
Track Width Retracted approx	780 mm	Hydraulic Tank Capacity	approx 85 L
Track Width Extended approx	1.170 mm	Cutter Wheel Diameter	722 mm
Driving Speed	approx 4 km/h	Cutter Wheel Strength	20 mm
Length x Height	3.400 x 1.900 mm	Number of Cutting Teeth	10
Approx Weight	1.900 kg	Cutter Wheel Swing Width	1.650 mm
		Workdepth under Planum	580 mm
		Workdepth over Planum	300 mm

Your local dealer:



JENSEN Service GmbH  
Bahnhofstraße 20 - 22  
D-24975 Maasbüll  
Tel. +49 46 34 - 93 700  
Fax+49 46 34 - 10 25  
E-Mail: [info@jensen-service.de](mailto:info@jensen-service.de)  
[www.jensen-service.de](http://www.jensen-service.de)



## Our Commitments

We always endeavour to provide our customers an „All-round Carefree Package“.

We guarantee a decades long spare parts supply for our standard machines aswell as individual manufactured machines.

All machines are manufactured in our factory and sold by experienced and knowledgeable dealers and importers who provide professional advice and excellent service .

**You can also make the right decision  
and choose ....**

